



www.eee-books.com

لتحميل المزيد من الكتب والمراجع باللغة العربية

تابعونا على

موقع عالم الهندسة الكهربائية

www.eee-books.com

جروب عالم الهندسة الكهربائية على الفيس بوك

www.facebook.com/groups/EEE.Arabic

قياس الحرارة

Temperature Measurement



Eng. Mahmoud Abdel Fatah Ahmed
mahmodcontrol@yahoo.com

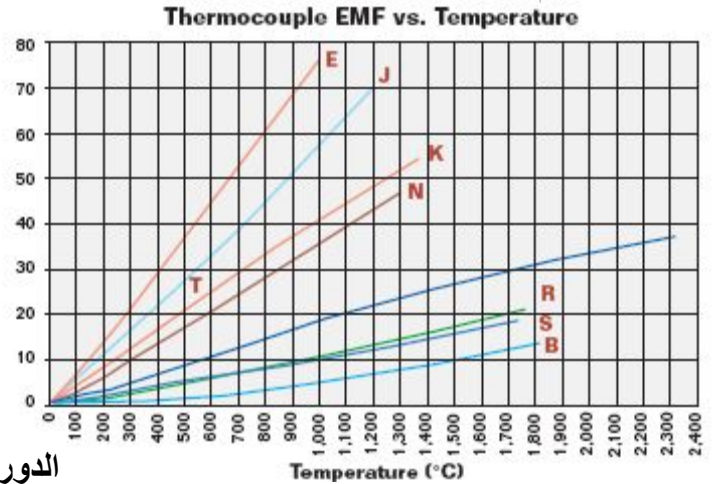

الدورة التدريبية لمهندسين الأجهزة الدقيقة 2009/2010

إعداد وتنفيذ / المهندس / محمود عبد الفتاح أحمد أبو الفتوح
المدرّب المصري للأجهزة الدقيقة

E.Mail mahmodcontrol@yahoo.com

قياس الحرارة Temperature Measurement - شركة النفط السورية (مديرية حقول الحسكة - الرميلان)
إعداد وتنفيذ / المهندس / محمود عبد الفتاح أحمد أبو الفتوح / المدرّب المصري للأجهزة الدقيقة

2009/2010

Mob. 01148695492

E.Mail mahmodcontrol@yahoo.com

قياس الحرارة

Temperature Measurement

الحرارة هي من أهم المتغيرات الطبيعية Physical Variable التي يتم قياسها في العمليات الصناعية والإنتاجية والكثير من المجالات العامة .
قياس الحرارة والتحكم فيها له أهمية عظمى في ضبط ظروف التشغيل المناسبة لضمان الحصول على المنتج وبالمواصفات الصحيحة ، أيضاً ضمان عدم تجاوز الحرارة الحدود الآمنة لسلامة الأفراد والمعدات .

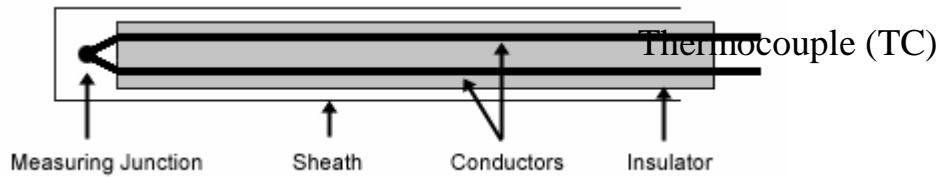

تتنوع وسائل قياس الحرارة حسب نوع الاستخدام ، ولهذا يجب معرفة الوسيلة المناسبة وإختيارها وتفضيلها حتى نحصل على القياسات المطلوبة وبالتكلفة المناسبة .
وحدة قياس الحرارة هي درجة مئوية (Celsius) °C أو فهرنهايتية (Fahrenheit) °F وللتحويل بينهما

Degrees Celsius	Degrees Fahrenheit	$(^{\circ}\text{C} \times 9/5) + 32$	نتبع علاقة التحويل
Degrees Fahrenheit	Degrees Celsius	$(^{\circ}\text{F} - 32) \times 5/9$	

قياس الحرارة Temperature Measurement - شركة النفط السورية (مديرية حقول الحسكة - الرميلان)
إعداد وتنفيذ / المهندس / محمود عبد الفتاح أحمد أبو الفتوح / المدرب المصري للأجهزة الدقيقة

قياس الحرارة بالإزدواج الحرارى

Thermocouple (TC)

الإستخدام الرئيسى للإزدواج الحرارى هو فى المجالات الصناعية والبتروولية .
نستخدم الإزدواج الحرارى لقياس مدى واسع من درجات الحرارة ، حيث نستطيع إستخدامه لقياس حرارة
تصل إلى 1800°C بينما يقتصر إستخدام الـ RTD على درجات حرارة حتى 700°C

Thermocouples are very rugged and inexpensive and can operate over a wide temperature range.

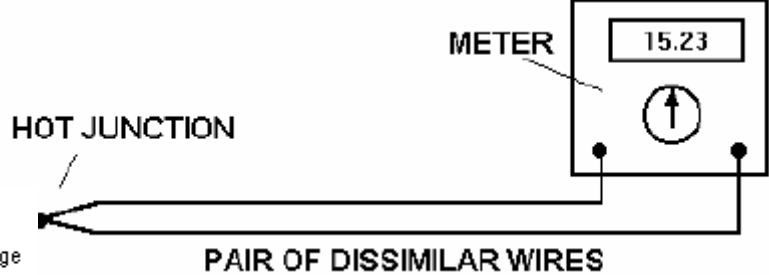
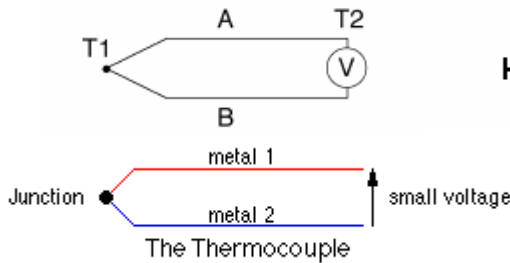
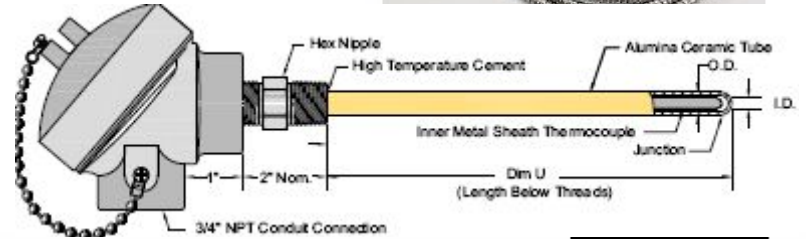
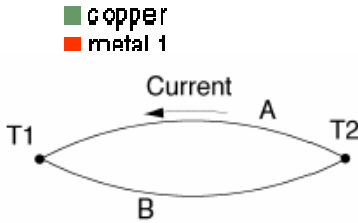
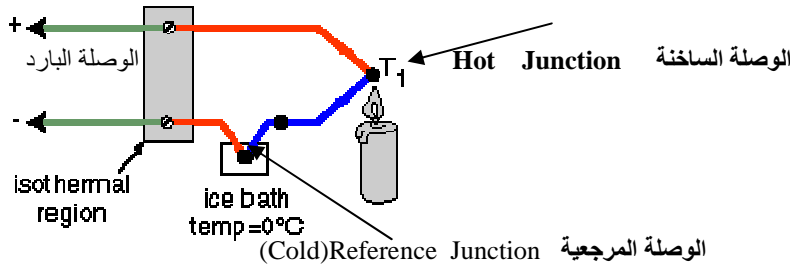

يعتمد مبدأ عمل الإزدواج الحرارى على الآتى :

عند إتصال سلكين من معدنين

مختلفين لهما خواص كهربية غير متشابهة **Dissimilar Electrical Properties**

من كلا طرفيهما ليكونا نقطتى إتصال **Two Junctions**

عند تعرض إحدى النقطتين لدرجة حرارة تختلف عن الأخرى ، تتولد قوة دافعة

كهربية **Electromotive Force** (مللى فولت mV) تزداد بزيادة فرق الحرارة

بين نقطتى إتصال طرفى السلكين **Two Junctions** .

Types of Thermocouples أنواع الإزدواجات الحرارية

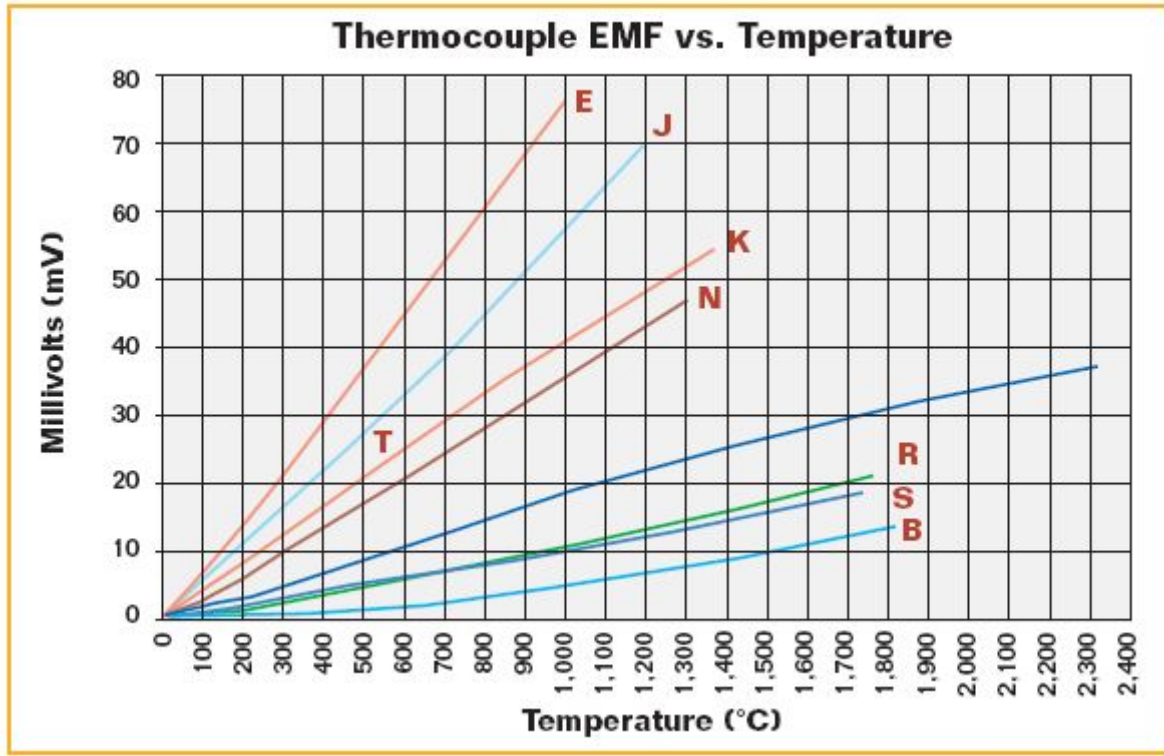
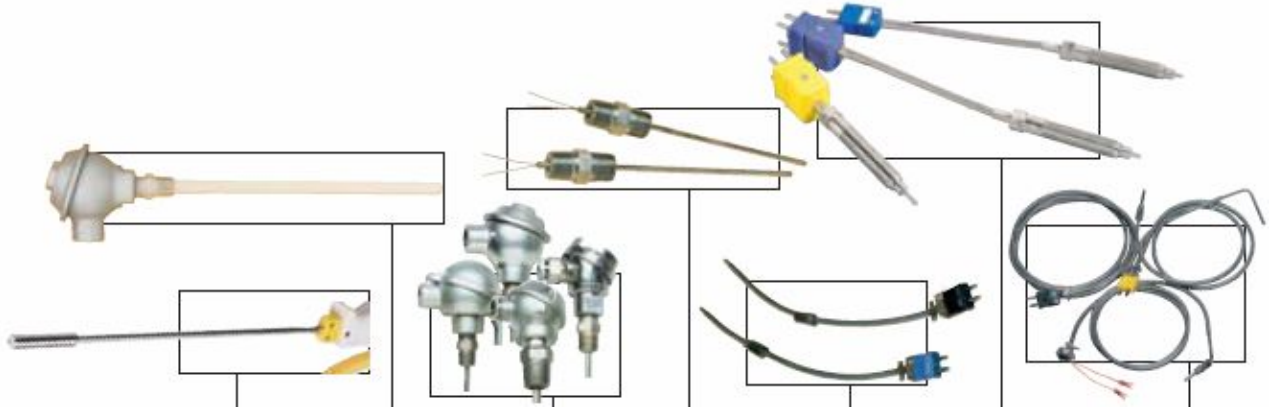

يوضح الشكل أنواع الإزدواجات الحرارية ومدى قياسها والمللى فولت mV المناظر لدرجة الحرارة °C
 تم تصنيف الإزدواجات الحرارية وخواصها وشفرة ألوانها في نظم قياسية عالمية Standardized هي :
 - النظام الأمريكى (الأكثر إنتشاراً) وهو ASTM

ASTM = American Society for Testing and Materials

IEC = International Electrotechnical Commission

- النظام الأوروبى وهو IEC

JIS = Japanese Industrial Standards

- النظام اليابانى وهو JIS

By Eng. Mahmoud Abdel Fatah Ahmed
 mahmodcontrol@yahoo.com
 Mob. 01148695492

مدى قياس Temperature Range درجات الحرارة

للإزدواجات الحرارية TC

وقيمة السماحية Tolerance المناظرة

Thermocouple Tolerances (Reference Junction at 0°C)

American Limits of Error ASTM E230-ANSI MC 96.1

ANSI Code		Standard Limits [†]		Special Limits [†]	
J	Temp Range	>0 to 750°C	>32 to 1382°F	0 to 750°C	32 to 1382°F
	Tolerance Value	2.2°C or 0.75%	4.0°F or 0.75%	1.1°C or 0.4%	2.0°F or 0.4%
K	Temp Range	>0 to 1250°C	>32 to 2282°F	0 to 1250°C	32 to 2282°F
	Tolerance Value	2.2°C or 0.75%	4.0°F or 0.75%	1.1°C or 0.4%	2.0°F or 0.4%
	Temp. Range* Tolerance Value	-200 to 0°C 2.2°C or 2.0%	-328 to 32°F 4.0°F or 2.0%		
T	Temp Range	>0 to 350°C	>32 to 662°F	0 to 350°C	32 to 662°F
	Tolerance Value	1.0°C or 0.75%	1.8°F or 0.75%	0.5°C or 0.4%	1°F or 0.4%
	Temp. Range* Tolerance Value	-200 to 0°C 1.0°C or 1.5%	-328 to 32°F 1.8°F or 1.5%		
E	Temp Range	>0 to 900°C	>32 to 1652	0 to 900°C	32 to 1652°F
	Tolerance Value	1.7°C or 0.5%	3°F or 0.5%	1.0°C or 0.4%	1.8°F or 0.4%
	Temp. Range* Tolerance Value	-200 to 0°C 1.7°C or 1.0%	-328 to 32°F 3°F or 1.0%		
N	Temp Range	>0 to 1300°C	>32 to 2372°F	0 to 1300°C	32 to 2372°F
	Tolerance Value	2.2°C or 0.75%	4.0°F or 0.75%	1.1°C or 0.4%	2.0°F or 0.4%
	Temp. Range* Tolerance Value	-270 to 0°C 2.2°C or 2.0%	-454 to 32°F 4.0°F or 2.0%		
R S	Temp Range	0 to 1450°C	32 to 2642°F	0 to 1450°C	32 to 2642°F
	Tolerance Value	1.5°C or 0.25%	2.7°F or 0.25%	0.6°C or 0.1%	1°F or 0.1%
B	Temp Range	800 to 1700°C	1472 to 3092°F	Not Established	
	Tolerance Value	0.5%	0.9°F		
G*C*D*	Temp Range	0 to 2320°C	32 to 4208°F	Not Established	
	Tolerance Value	4.5°C or 1.0%	0.9°F		

* Not official symbol or standard designation † Whichever value is greater.

Note: Material is normally selected to meet tolerances above 0°C. If thermocouples are needed to meet tolerances below 0°C, the purchaser shall state this as selection of material is usually required.

IEC Tolerance Class EN 60584-2; JIS C 1602

IEC Code		Class 1	Class 2	Class 3 [†]
J	Temp Range	-40 to 375°C	-40 to 333°C	Not Established
	Tolerance Value	±1.5°C	±2.5°C	
	Temp. Range	375 to 750°C	333 to 750°C	
	Tolerance Value	±0.4% Reading	±0.75% Reading	
K N	Temp Range	-40 to 375°C	-40 to 333°C	-167 to 40°C
	Tolerance Value	±1.5°C	±2.5°C	±2.5°C
	Temp. Range	375 to 1000°C	333 to 1200°C	-200 to -167°C
	Tolerance Value	±0.4%	±0.75% Reading	±1.5% Reading
T	Temp Range	-40 to 125°C	-40 to 133°C	-67 to 40°C
	Tolerance Value	±0.5°C	±1°C	±1°C
	Temp. Range	125 to 350°C	133 to 350°C	-200 to -67°C
	Tolerance Value	±0.4% Reading	±0.75% Reading	±1.5% Reading
E	Temp Range	-40 to 375°C	-40 to 333°C	-167 to 40°C
	Tolerance Value	±1.5°C	±2.5°C	±2.5°C
	Temp. Range	375 to 800°C	333 to 900°C	-200 to -167°C
	Tolerance Value	±0.4% Reading	±0.75% Reading	±1.5% Reading
R S	Temp Range	0 to 1100°C	0 to 600°C	Not Established
	Tolerance Value	±1°C	±1.5°C	
	Temp. Range	1100 to 1600°C	600 to 1600°C	
	Tolerance Value	±[1 + 0.3% x (Rdg-1100)]°C	±0.25% Reading	

By Eng. Mahmoud Abdel Fatah Ahmed
mahmodcontrol@yahoo.com
Mob. 01148695492

قياس الحرارة Temperature Measurement - شركة النفط السورية (مديرية حقول الحسكة - الرميلان)
إعداد وتنفيذ / المهندس / محمود عبد الفتاح أحمد أبو الفتوح / المدرب المصري للأجهزة الدقيقة

أقصى درجة حرارة عمل للعزل Insulation نوع أوكسيد الماغنيسيوم MgO هو 1650°C

Reference Guide

- ✓ Properties of the sheath material
- ✓ Diameter and construction of thermocouple assembly

Temperature Range

OMEGA CLAD® is a three-part system composed of compacted MgO insulation, thermocouple wire and metal sheath. Four factors determine the useful service temperature for OMEGA CLAD® assemblies.

- ✓ Range for the thermocouple wire (see table of error)
- ✓ Maximum service temperature of insulation. In the case of MgO, this is in excess of 1650°C (3000°F)

Sheath Material Specifications

Material	Melting Point (°C/°F)	Continuous Maximum Temp. (°C/°F)	Tensile (PSI) Strength	
			@ 93°C (200°F)	@ 537°C (1000°F)
304 SS	1405/2560	900/1650	68,000	15,000
310 SS	1405/2560	1150/2100	75,000	27,500
316 SS	1370/2500	925/1700	75,000	23,000
321 SS	1400/2550	870/1600	70,000	17,000
Hastelloy X	1260/2300	1200/2200	55,100	35,500
Inconel*	1400/2550	1150/2100	39,000	5,000
SUPER XL	1400/2550	1204/2200	70,000	17,000

*Oxidizing, Vacuum or Inert atmosphere only

Conductor Size Equivalents

Gage No.	AWG		SWG		GAGE No.	AWG		SWG		Twisted Shielded Wire
	inches	mm	inches	mm		inches	mm	inches	mm	
0	0.3249	8.25	0.324	8.23	23	0.0226	0.574	0.024	0.610	
1	0.2893	7.35	0.300	7.62	24	0.0201	0.511	0.022	0.559	
2	0.2576	6.54	0.276	7.01	25	0.0179	0.455	0.020	0.508	
3	0.2294	5.83	0.252	6.40	26	0.0159	0.404	0.0180	0.457	
4	0.2043	5.19	0.232	5.89	27	0.0142	0.361	0.0164	0.417	
5	0.1819	4.62	0.212	5.38	28	0.0126	0.320	0.0148	0.376	
6	0.1620	4.11	0.192	4.88	29	0.0113	0.287	0.0136	0.345	
7	0.1443	3.67	0.176	4.47	30	0.0100	0.254	0.0124	0.315	
8	0.1285	3.26	0.160	4.06	31	0.0089	0.226	0.0116	0.295	
9	0.1144	2.91	0.144	3.66	32	0.0080	0.203	0.0108	0.274	
10	0.1019	2.59	0.128	3.25	33	0.0071	0.180	0.0100	0.254	
11	0.0907	2.30	0.116	2.95	34	0.0063	0.160	0.0092	0.234	
12	0.0808	2.05	0.104	2.64	35	0.0056	0.142	0.0084	0.213	
13	0.0720	1.83	0.092	2.34	36	0.0050	0.127	0.0076	0.193	
14	0.0641	1.63	0.080	2.03	37	0.0045	0.114	0.0068	0.173	
15	0.0571	1.45	0.072	1.83	38	0.0040	0.102	0.0060	0.152	
16	0.0508	1.29	0.064	1.63	39	0.0035	0.089	0.0052	0.132	
17	0.0453	1.15	0.056	1.42	40	0.0031	0.079	0.0048	0.122	
18	0.0403	1.02	0.048	1.22	41	0.0028	0.071	0.0044	0.112	
19	0.0359	0.912	0.040	1.02	42	0.0025	0.064	0.0040	0.102	
20	0.0320	0.813	0.036	0.914	43	0.0022	0.056	0.0036	0.091	
21	0.0285	0.724	0.032	0.813	44	0.0020	0.051	0.0032	0.081	
22	0.0253	0.643	0.028	0.711	45	0.0018	0.046	0.0028	0.071	

AWG = American Wire Gage
SWG = (British) Standard Wire Gage

To convert from AWG to SWG: Determine wire diameter in inches (mm) from appropriate AWG. To convert 30 AWG to SWG, determine that 30 AWG is 0.0100", which is equivalent to 33 SWG

Upper Temperature Limit in °C (°F) of OMEGA CLAD® Vs. Sheath Diameter

Sheath T/C Dia.	0.020"	0.032"	0.040"	0.062"	0.093"	0.125"	0.188"	0.250"
	0.5 mm	0.8 mm	1.0 mm	1.6 mm	2.4 mm	3.2 mm	4.8 mm	6.3 mm
J	260 (500)	260 (500)	260 (500)	440 (825)	480 (900)	520 (970)	620 (1150)	720 (1300)
K & N	700 (1290)	700 (1290)	700 (1290)	920 (1690)	1000 (1830)	1070 (1960)	1150 (2100)	1150 (2100)
E	300 (570)	300 (570)	300 (570)	510 (950)	580 (1075)	650 (1200)	730 (1350)	820 (1510)
T	260 (500)	260 (500)	260 (500)	260 (500)	260 (500)	315 (600)	370 (700)	370 (700)

Bends Easily!

H-7

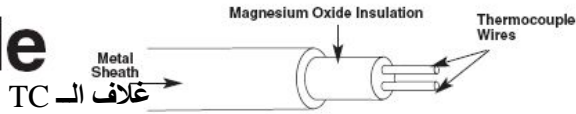

Upper Temperature Limit in °C (°F) of Protected Bare Wire Thermocouples Vs. Wire Diameter

T/C Type	Wire Size						
	8 AWG 0.128"	14 AWG 0.064"	20 AWG 0.032"	24 AWG 0.020"	28 AWG 0.013"	30 AWG 0.010"	36 AWG 0.005"
J	760 (1400)	590 (1100)	480 (900)	370 (700)	370 (700)	320 (600)	315 (590)
K	1260 (2300)	1090 (2000)	980 (1800)	870 (1600)	870 (1600)	760 (1400)	590 (1100)
E	870 (1600)	650 (1200)	540 (1000)	430 (800)	430 (800)	370 (700)	320 (600)
T	370 (700)	370 (700)	260 (500)	200 (400)	200 (400)	150 (300)	
RX/SX	200 (400)	200 (400)	200 (400)	200 (400)	200 (400)	150 (300)	
N	1260 (2300)	1090 (2000)	980 (1800)	980 (1800)	980 (1800)	870 (1600)	
CX	472 (900)	472 (900)	472 (900)	472 (900)	472 (900)	400 (752)	

Common Thermocouple Junctions

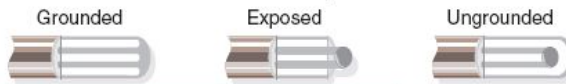

By Eng. Mahmoud Abdel Fatah Ahmed
mahmodcontrol@yahoo.com
Mob. 01148695492

حساس (بروب Probe) الإزدواج الحرارى TC

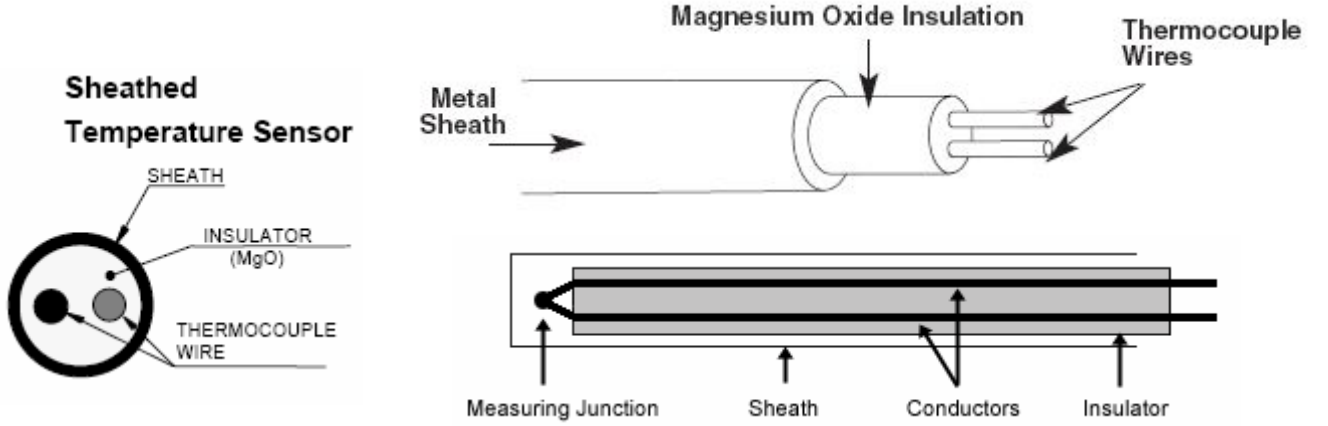

Sheath Material Specifications

Material	Melting Point (°C/°F)	Continuous Maximum Temp. (°C/°F)	Tensile (PSI) Strength	
			@ 93°C (200°F)	@ 537°C (1000°F)
304 SS	1405/2560	900/1650	68,000	15,000
310 SS	1405/2560	1150/2100	75,000	27,500
316 SS	1370/2500	925/1700	75,000	23,000
321 SS	1400/2550	870/1600	70,000	17,000
Hastelloy X	1260/2300	1200/2200	55,100	35,500
Inconel*	1400/2550	1150/2100	39,000	5,000
SUPER XL	1400/2550	1204/2200	70,000	17,000

By Eng. Mahmoud Abdel Fatah Ahmed
mahmodcontrol@yahoo.com
Mob. 01148695492

Thermocouple Probe

A thermocouple probe consists of thermocouple wire housed inside a metallic tube. يتكون بروب الـ TC من سلك الإزدواج الحرارى بداخل أنبوبة معدنية .

هذه الكلمة تعني الجدار المعدنى للأنبوبة الحاوية لـ TC ، ويجب الإهتمام بذكر نوع مادتها عند الحاجة لإعداد طلب شراء الـ TC وعامة تكون مادة الـ Sheath من الصلب stainless steel بدرجاته كما بالجدول حسب درجة الحرارة

و مادة الإنكونيل Inconel لمدى درجات الحرارة العالية higher temperature ranges أيضاً يجب إختيار مادة العازل Insulator (لعزل سلك الإزدواج عن الـ Sheath) وهى كما بالشكل مادة أوكسيد الماغنيسيوم التى تتحمل العمل فى درجة حرارة 1650°C

The wall of the tube is referred to as the sheath of the probe.

Common sheath materials include stainless steel and Inconel.

Inconel supports higher temperature ranges than stainless steel, however, stainless steel is often preferred because of its broad chemical compatibility.

تطبيقات عملية على استخدام الإزدواج الحرارى TC

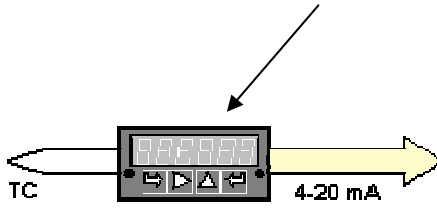

يوضح الشكل توصيل الـ TC مع جهاز ديجيتال
يبين درجة الحرارة ويعمل أيضاً ترانسميتر يعطى
إشارة خرج 4 – 20 mA

By Eng. Mahmoud Abdel Fatah Ahmed
mahmodcontrol@yahoo.com
Mob. 01148695492

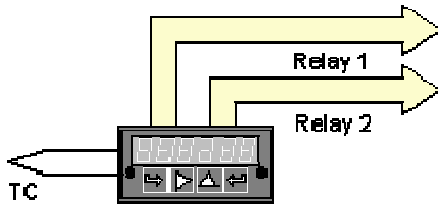

يوضح الشكل توصيل الـ TC مع جهاز ديجيتال
يبين درجة الحرارة ويعطى إشارتين خرج
إحدهما لتشغيل الريلاى الأول Relay 1
والثانية لتشغيل الريلاى الثانى Relay 2
وهذه الإشارات نستخدمها للتحكم فى الحرارة أو الإنذار Alarm أو غير ذلك حسب الحاجة

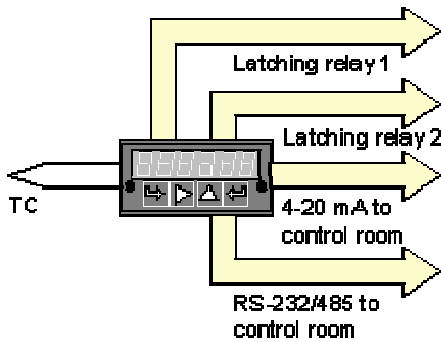

يوضح الشكل توصيل الـ TC مع جهاز ديجيتال
يبين درجة الحرارة ويعطى إشارات متعددة
لتشغيل الريلاى الأول Relay 1 و الريلاى الثانى Relay 2
وإشارة خرج 4 – 20 mA لإستخدامه فى غرفة التحكم
للبيان أو التسجيل أو التحكم أو غير ذلك ، كما يعطى الجهاز
أيضاً خرج ديجيتال لتوصيله مثلاً بأجهزة الكمبيوتر PC

قياس الحرارة بالمقاومة الكهربائية (RTD) Resistance Temperature Detector

يعتمد عمل حساس الحرارة Temperature sensor الـ RTD على تغير مقاومته الكهربائية Ω بتغير درجة الحرارة $^{\circ}\text{C}$.

Resistance Temperature Detectors (RTDs) are temperature sensors that contain a resistor that changes resistance value as its temperature changes.

وتستخدم حساسات الحرارة RTD عامة في المدى من -200 to 850°C ولكن يفضل الآتي :

- أنواع RTD المصنوعة رقائقياً Thin-film تستخدم في المدى -50 to 500°C
- أنواع RTD المصنوعة على شكل wire-wound تستخدم في المدى -200 to 850°

يستخدم حساس Sensor المقاومة الكهربائية RTD لقياس الحرارة هو أكثر الوسائل إستخداماً مثل الإزدواج الحرارى Thermocouple .

ويزداد حالياً الإتجاه لإستخدام الـ RTD نظراً للدقة الممتازة Excellent accuracy في مدى واسع من قياس درجة الحرارة ، والمنافسة في السعر ، هذا بالإضافة إلى صغر حجمها وعدم الحاجة إلى أسلاك تمديد خاصة مثل الإزدواج الحرارى ، كما أن الـ RTD أكثر دقة من الـ Thermocouple



Highly accurate RTD probes and sensors and specialty design for unique applications.

RTD Elements



Thin film and ceramic wire RTD Elements are perfect for those tight work spaces when you need precise measurements.



PR-12
Industrial RTD (PT100)
Probes with Cast Iron
Protection Head

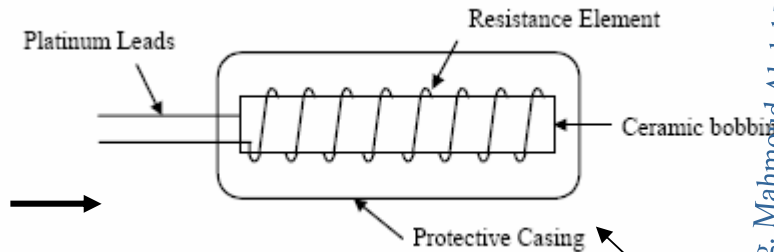

مقاومة RTD نوع Pt100 قيمتها 100Ω عند الصفر المنوى

يوضح الشكل مقاومة مصنوعة من سلك بلاتين Platinum wire ملفوف على عازل سيرميك Ceramic وتعتبر المقاومة البلاتينية هي الأكثر إستخداماً لأنها الأكثر خطية Near Linearity على مدى واسع من قياسات الحرارة ، كما أنها تمتاز بالثبات على المدى الطويل .

وهناك الآن RTD مصنوعة من مواد أخرى تنافس في السعر المقاومة البلاتينية مثل الـ RTD المصنوعة من النيكل أو النحاس .
ولكن يجب مراعاة الآتي :

Other materials such as nickel, copper, and nickel-iron alloy have also been used for RTDs.

However, these materials are not commonly used since they have lower temperature capabilities and are not as stable or repeatable as platinum.

العلاقة بين المقاومة البلاتينية (Pt100) ودرجة الحرارة

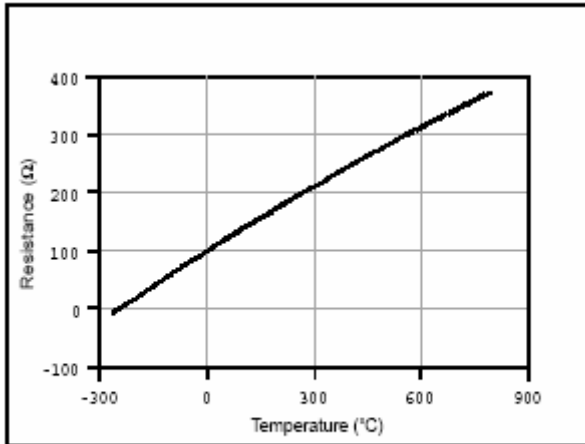

Resistance-Temperature Curve for a 100 Ω Platinum RTD, $\alpha = 0.00385$

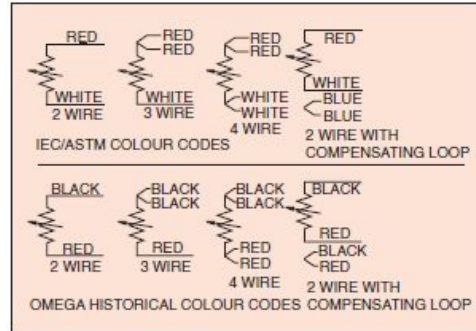

يوضح الشكل العلاقة بين قيمة المقاومة البلاتينية Pt100 وبين درجة الحرارة .

RTD standards

There are two standards for platinum RTDs:

the European standard (also known as the DIN or IEC standard) and the American standard.

The European standard, also known as the DIN or IEC standard, is considered the world-wide standard for platinum RTDs.

This standard, DIN/IEC 60751 (or simply IEC751), requires the RTD to have an electrical resistance of 100.00 Ω at 0°C and a temperature coefficient of resistance (TCR) of 0.00385 Ω/Ω/°C between 0 and 100°C.

There are three resistance tolerances for Thin Film RTDs specified in IEC60751:

Class AA (Formerly 1/3B) = $\pm(0.1+0.0017*t)^{\circ}\text{C}$ or $100.00 \pm 0.04\Omega$ at 0°C

Class A = $\pm(0.15+0.002*t)^{\circ}\text{C}$ or $100.00 \pm 0.06\Omega$ at 0°C

Class B = $\pm(0.3+0.005*t)^{\circ}\text{C}$ or $100.00 \pm 0.12\Omega$ at 0°C

By Eng. Mahmoud Abdel Fatah Ahmed
mahmodcontrol@yahoo.com
Mob. 01148695492

إستخدام الـ RTD

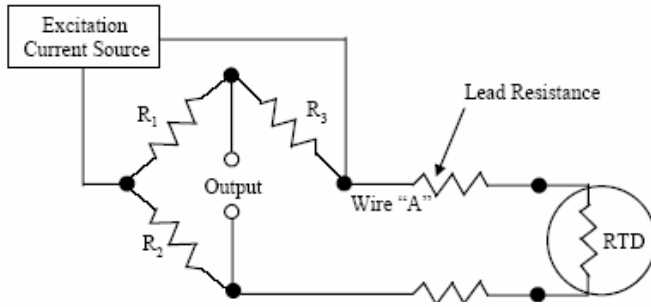

Two-Wire RTD Measurement

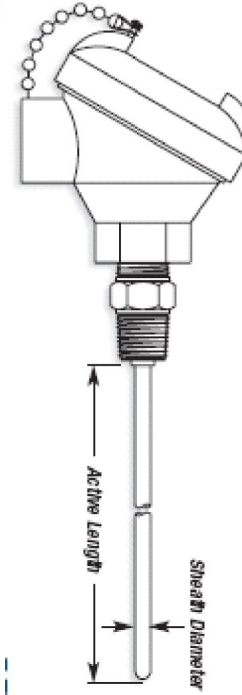
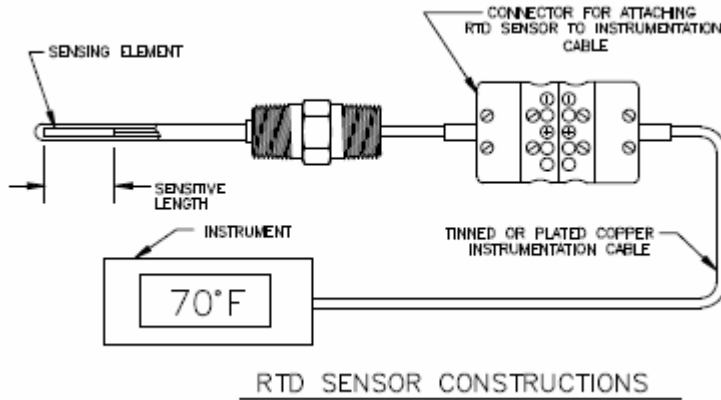
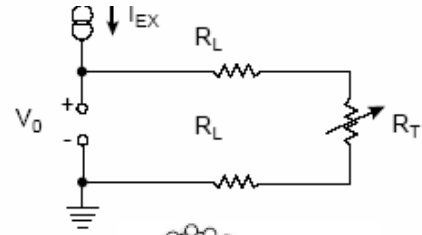

By Eng. Mahmoud Abdel Fatah Ahmed
mahmodcontrol@yahoo.com
Mob. 01148695492

Material	Usable Temperature Range
Platinum	-450°F To 1200°F
Nickel	-150°F To 600°F
Copper	-100°F To 300°F
Nickel/Iron	32°F To 400°F

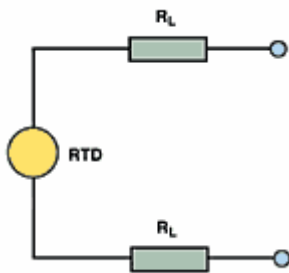

مقاومة الـ RTD ثنائية الأطراف Two wire
نظراً لإعتماد القياس على قيمة مقاومة الـ RTD فإن دقة القياس تتأثر إذا زاد طول أسلاك التمديد عن ثلاثة أمتار ، حيث تصاف قيمة مقاومة أسلاك التمديد (R_L) إلى قيمة المقاومة RTD وبالتالي يظهر خطأ في القراءة على جهاز بيان الحرارة .

ولهذا يكون من الأفضل استخدام RTD ذو ثلاث أطراف Three Wire RTD

RTD

Resistance varies with Temperature

Platinum 100 Ohm at 0°C

Very accurate

Very stable

The most common material from which RTD's are made is Platinum

مقاومة الـ RTD ذو ثلاث أطراف Three Wire RTD

يستخدم هذا النوع كثيراً للحصول على دقة عالية مع السعر الإقتصادي الأفضل بالمقارنة بالمقاومة ذات الأربعة أطراف Four Wire RTD.

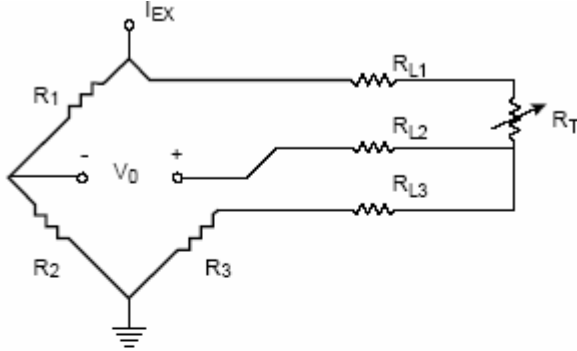

a. Three-Wire RTD in a Wheatstone Configuration

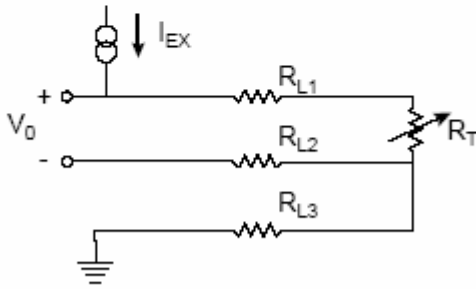

Three-Wire RTD with a Current Excitation Source

في الشكل المقابل يتم تعويض مقاومة أسلاك التمديد Lead Resistance كما يلي :

تأثير المقاومة R_{L1} و R_2 يلغى كل منهما الآخر لأنهما يقعان على زراعتين متضادتين في قنطرة هويتستون Wheatston bridge

تبقى المقاومة R_{L2} ولكنها لا تضيف خطأ مؤثر لأنها تعبر تيار كهربى قليل .

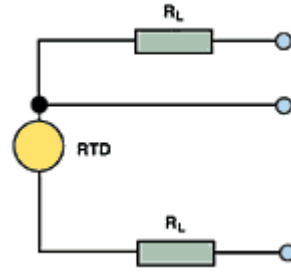

By Eng. Mahmoud Abdel Fatah Ahmed
mahmodcontrol@yahoo.com
Mob. 01148695492

مقاومة الـ RTD رباعية الأطراف Four wire

هى الأفضل و الأكثر دقة لتعويض تأثير خطأ القياس الناتج عن مقاومة أسلاك التمديد Lead Resistance

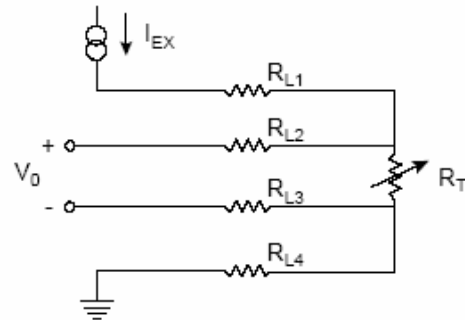
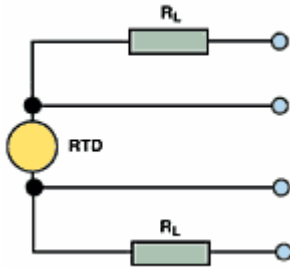

يمر التيار الكهربى فى المقاومتين R_{L1} و R_{L4} بينما يتم قياس فولت على طرفى المقاومة RTD وحيث أن التيار الذى يمر فى المقاومة RTD الحساسة وهى R_T صغير جدا فإن تأثير خطأ مقاومة سلكى التمديد R_{L2} و R_{L3} يكون مهمل ولا يذكر .

Platinum RTD's are made of 99.99% pure platinum (PT).

RTD's are 100, 500, and 1000 Ohms The most common resistances of Platinum (Ω 's) at 0° Centigrade.

of 138.5 Ohms at 100 °C. A 100 Ohm PT RTD will have a resistance

Why use an RTD instead of a thermocouple or thermistor sensor?

Each type of temperature sensor has a particular set of conditions for which it is best suited.

RTDs offer several advantages:

- A wide temperature range (-50 to 500°C for thin-film and -200 to 850°C for wire-wound).
- Good accuracy (better than thermocouples)
- Good interchangeability
- Long-term stability

When made using metals such as platinum, they are very stable and are not affected by corrosion or oxidation.

Other materials such as nickel, copper, and nickel-iron alloy have also been used for RTDs.

However, these materials are not commonly used since they have lower temperature capabilities and are not as stable or repeatable as platinum.

Temperature Sensor Selection Guide		
	RTD	Thermocouple
Temperature Range	-200°C to 850°C	-190°C to 1821°C
	-328°F to 1562°F	-310°F to 3308°F
Accuracy	±0.001°F to 0.1°F	±1°F to 10°F
Response Time	Moderate	Fast
Stability	Stable over long periods	Not as stable
	<0.1% error/5 yr.	1°F error/yr.
Linearity	Best	Moderate
Sensitivity	High sensitivity	Low sensitivity

RTD

Wiring Arrangement

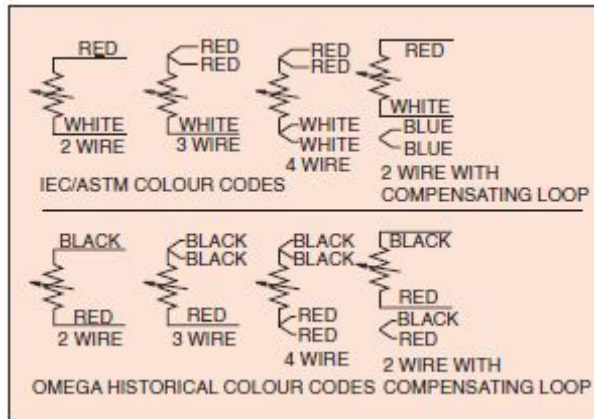

By Eng. Mahmoud Abdel Fatah Ahmed
 mahmodcontrol@yahoo.com
 Mob. 01148695492

RTDs operate by exhibiting an increase in resistivity with an increase in temperature. RTDs are most commonly made from platinum, nickel, or copper. Copper and nickel versions operate at lower temperature ranges and are less expensive than platinum. Platinum is the most versatile material because of its wide temperature range (-200°C to 850°C), excellent repeatability, stability, and resistance to chemicals and corrosion. Platinum RTDs are available in 100 (ohm), 200 (ohm), 500 (ohm), and 1000 (ohm) nominal resistance values at 0°C , of which the 100 (ohm) is the most popular.

The basic construction of an RTD is quite simple. A sensing element is connected to lead wires and supported by an insulator such as glass, mica, or a ceramic placed inside a protective sheath (see Figure 1,). The detectors are available in 2-, 3-, and 4-wire configurations.

The 2-wire version is well suited to applications where the sensor is directly connected to the receiver to prevent lead length resistance errors, a problem that led to the development of more accurate 3- and 4-wire configurations. When there is a significant distance between the sensor and the receiving instrument, 3-wire units are used. Their accuracy, although less than that of a 4-wire detector, is sufficient for many industrial applications.

In the 4-wire configuration, one pair of leads supplies the excitation current to the RTD and the other pair measures voltage across it. This technique significantly minimizes lead voltage drop and provides high accuracy.

مثال عملي لأحد الأجهزة الحديثة للبيان والتحكم في الحرارة
 باستخدام حساسات RTD Sensors
 وحساسات الإزدواج الحرارى TC
 جهاز ديجيتال للقياس والتحكم في الحرارة
 Digital temperature Indicator Controller

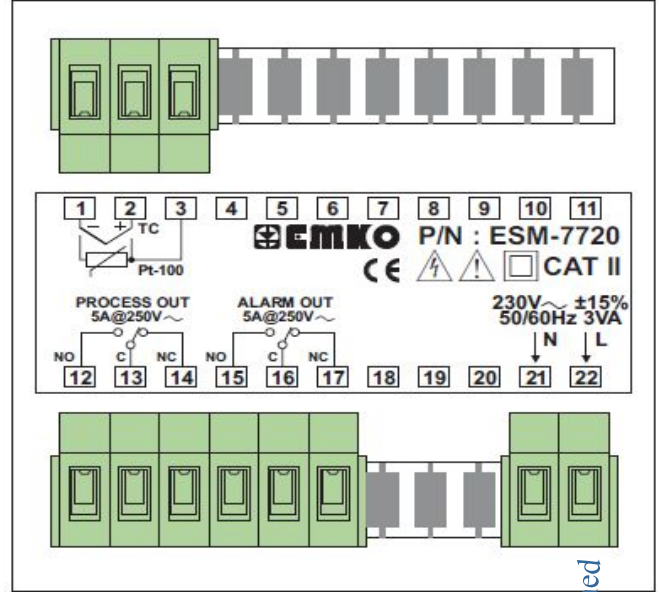

- 4 digits process(PV) and 4 digits process set value(SV) display
- Universal process input (TC, RTD)
- Configurable ON/OFF, P, PI, PD and PID control forms
- Adaptation of PID Coefficients to the system with Self-Tune operation (Step Response Tuning)
- Programmable Heating or Cooling Functions for Control Output
- Alarm Functions for Alarm Output

ESM-7720 series temperature controllers are designed for measuring and controlling a process value. They can be used in many applications with their universal process input, control outputs and selectable alarm functions.

Some application fields which they are used are below:

Application Fields	Application
Glass	PID Process Control
Plastic	
Petro-Chemistry	
Textile	
Automotive	
Machine production industries	

يمتاز الجهاز بالآتي :

- 1- عمومية الإستخدام لإستقبال إشارات دخل Input من حساسات الحرارة الآتية :
 - المقاومة الحرارية RTD والمعروفة عامة بال Pt 100
 - المزدوجات الحرارية TC بأنواعها
- 2- برمجة الجهاز للتحكم في عمليات التسخين والتبريد الصناعية والعامة
- 3- إعطاء إشارات إنذار لدرجات الحرارة التي تتعدى الدرجات الآمنة
- 4- السعر المناسب حوالي تسعون دولار أمريكي .

قياس الحرارة Temperature Measurement - شركة النفط السورية (مديرية حقول الحسكة - الرميلان)
 إعداد وتنفيذ / المهندس / محمود عبد الفتاح أحمد أبو الفتوح / المدرب المصرى للأجهزة الدقيقة

التوصيلات الكهربائية

Electrical Wiring Diagram

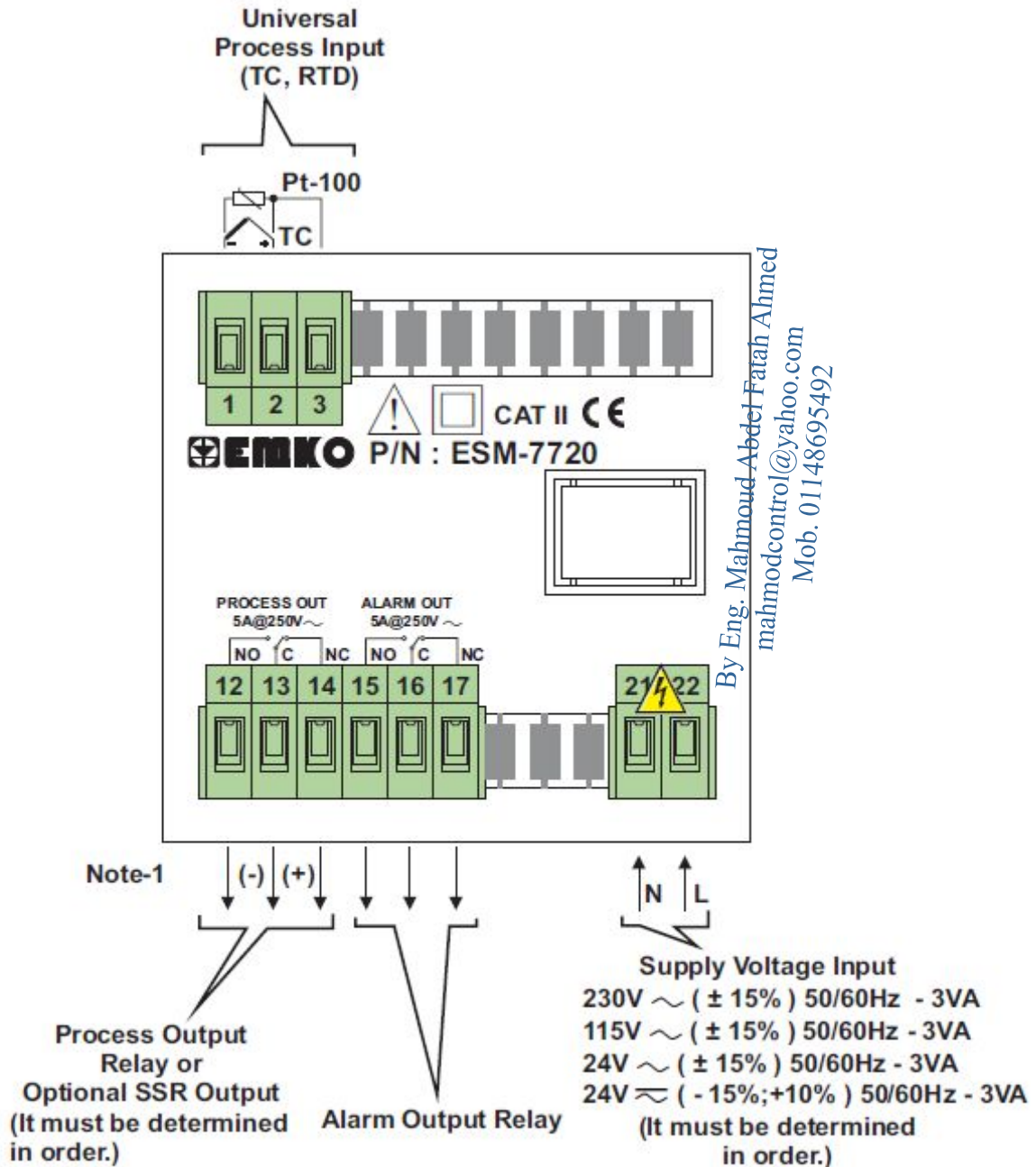

Note-1: Max 12V_{DC}, 10mA for SSR Driver Output

توصيلات دخل العملية لصناعية

Process Input Connection

TC Thermocouple Connection

توصيل الإزدواج الحرارى

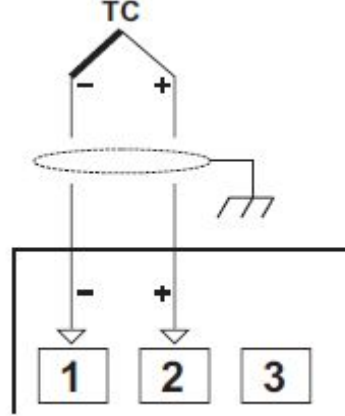

By Eng. Mahmoud Abdel Fatah Ahmed
mahmodcontrol@yahoo.com
Mob. 01148695492

RTD Connection

توصيل المقاومة الحرارية

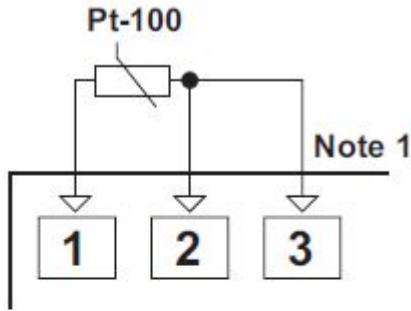

3-wire Pt-100 connection
(with line compensation)
(Max. Line impedance is 10 Ω)

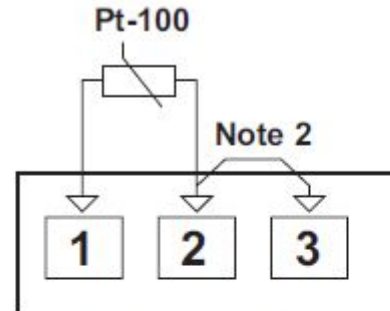

2-wire Pt-100 connection
(without line compensation)

Note 1 : In 3-wire system, use always cables of the same diameter (min 1mm²) Always use wires of the same gauge and type whether a 2-wire or 3-wire system.

Note 2 : Install a jumper between terminals 2 and 3 when using a 2-wire RTD.

Note 3 : If the distance is longer than 10 meters, use 3-wire system

توصيلات إشارة الخرج (ريلاي عادى) للعملية الصناعية Process Output (Relay) Connection

Process Output (Relay) Connection

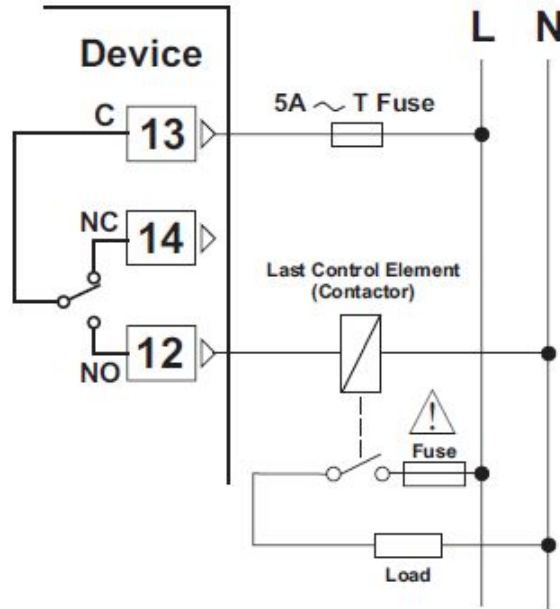

Fuses must be selected according to the application.

By Eng. Mahmoud Abdel Fatah Ahmed
mahmodcontrol@yahoo.com
Mob. 01148695492

Alarm Output (Relay) Connection

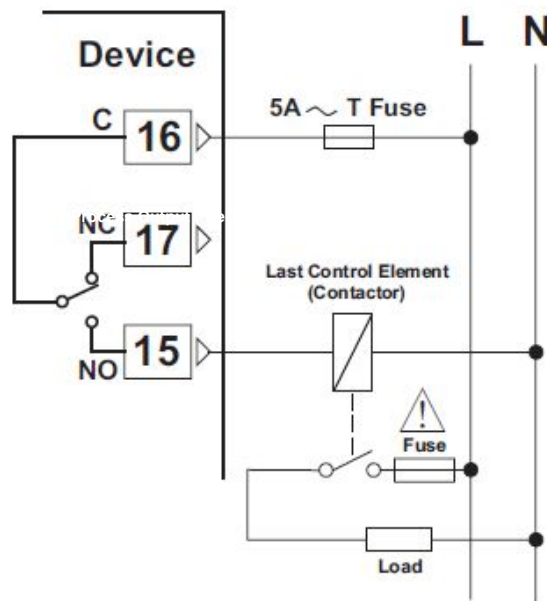

محول إشارة حساس الحرارة RTD الأوم Ω
 إلى إشارة كهربائية 0: 20 mA أو 4 : 20 mA أو 0: 10 VDC
Temperature signal converter for RTD sensors



Temperature signal converters
 for PT100 sensors , CC-E range

Approvals			
1604 Class I, Div. 2 ¹⁾			
Dimensions			
22.5 x 75 x 102 mm			
Supply voltage 24 V DC			
Type	Input signal	Output signal (linearized)	Order code
Universal device			
CC-E/RTD	PT100, 0...100 °C - 0...500 °C, -50 °C...+50 °C - -50 °C...+450 °C	0 - 10 V, 0 - 20 mA, 4 - 20 mA	1SVR 011 701 R2500 ¹⁾
Single-function devices			
CC-E RTD/V		0 - 10 V	1SVR 011 730 R2500
CC-E RTD/I	PT100, 0...100 °C	0 - 20 mA	1SVR 011 731 R1200
CC-E RTD/I		4 - 20 mA	1SVR 011 732 R1300
CC-E RTD/V		0 - 10 V	1SVR 011 733 R1400
CC-E RTD/I	PT100, -50...+50 °C	0 - 20 mA	1SVR 011 734 R1500
CC-E RTD/I		4 - 20 mA	1SVR 011 735 R1600
CC-E RTD/V		0 - 10 V	1SVR 011 736 R1700
CC-E RTD/I	PT100, 0...300 °C	0 - 20 mA	1SVR 011 737 R1000
CC-E RTD/I		4 - 20 mA	1SVR 011 738 R2100
CC-E RTD/V		0 - 10 V	1SVR 011 739 R2200
CC-E RTD/I	PT100, -50...+250 °C	0 - 20 mA	1SVR 011 740 R0700
CC-E RTD/I		4 - 20 mA	1SVR 011 741 R2400
Supply voltage 110-240 V AC			
Type	Input signal	Output signal (linearized)	Order code
Universal device			
CC-E/RTD	PT100, 0...100 °C - 0...500 °C, -50 °C...+50 °C - -50 °C...+450 °C	0 - 10 V, 0 - 20 mA, 4 - 20 mA	1SVR 011 706 R2200
Single-function devices			
CC-E RTD/V		0 - 10 V	1SVR 011 788 R2400
CC-E RTD/I	PT100, 0...100 °C	0 - 20 mA	1SVR 011 789 R2500
CC-E I			1SVR 011 790 R2200
CC-E I			1SVR 011 791 R1700
CC-E I			1SVR 011 792 R1000
CC-E I			1SVR 011 793 R1100
CC-E I			1SVR 011 794 R1200
CC-E I			1SVR 011 795 R1300
CC-E I			1SVR 011 796 R1400
CC-E I			1SVR 011 797 R1500
CC-E I			1SVR 011 798 R2600
CC-E I			1SVR 011 799 R2700

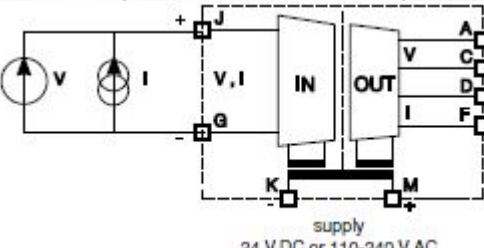



Ordering عمل طلب شراء

تستطيع الإستعانة بالجدول على اليسار
 لكتابة طلب شراء بالمواصفات الصحيحة
 والمناسبة للإستخدام في العمليات الصناعية
 بالشركات الصناعية والبتروولية .

By Eng. Mahmoud Abdel Fatah Ahmed
 mahmodcontrol@yahoo.com
 Mob. 01148695492



Temperature signal converters for thermocouples type J and K, CC-E range

Approvals	  1604 Class I, Div. 2 ¹⁾		
Dimensions	22,5 x 75 x 102 mm		
Supply voltage 24 V DC			
Type	Input signal	Output signal	Order code
<i>Universal device</i>			
CC-E/TC	Thermocouples type J (0...600°C), type K (0...1000 °C)	0 - 10 V, 0 - 20 mA, 4 - 20 mA	1SVR 011 702 R2600 ¹⁾
<i>Single-function devices</i>			
CC-E TC/V	type J 0...600 °C	0 - 10 V	1SVR 011 750 R0100
CC-E TC/I		0 - 20 mA	1SVR 011 751 R2600
CC-E TC/I		4 - 20 mA	1SVR 011 752 R2700
CC-E TC/V	type K 0...1000 °C	0 - 10 V	1SVR 011 753 R2000
CC-E TC/I		0 - 20 mA	1SVR 011 754 R2100
CC-E TC/I		4 - 20 mA	1SVR 011 755 R2200
Supply voltage 110-240 V AC			
Type	Input signal	Output signal	Order code
<i>Universal device</i>			
CC-E/TC	Thermocouples type J (0...600°C), type K (0...1000 °C)	0 - 10 V, 0 - 20 mA, 4 - 20 mA	1SVR 011 707 R2300
<i>Single-function devices</i>			
CC-E TC/V	type J 0...600 °C	0 - 10 V	1SVR 011 760 R0300
CC-E TC/I		0 - 20 mA	1SVR 011 761 R2000
CC-E TC/I		4 - 20 mA	1SVR 011 762 R2100
CC-E TC/V	type K 0...1000 °C	0 - 10 V	1SVR 011 763 R2200
CC-E TC/I		0 - 20 mA	1SVR 011 764 R2300
CC-E TC/I		4 - 20 mA	1SVR 011 765 R2400

By Eng. Mahmoud Abdel Fatah Ahmed
 mahmodcontrol@yahoo.com
 Mob. 01148695492

توصيلات إشارة الخرج (Solid State Relays ريلاي SSR) للعملية الصناعية

Process Output (SSR Driver) Connection

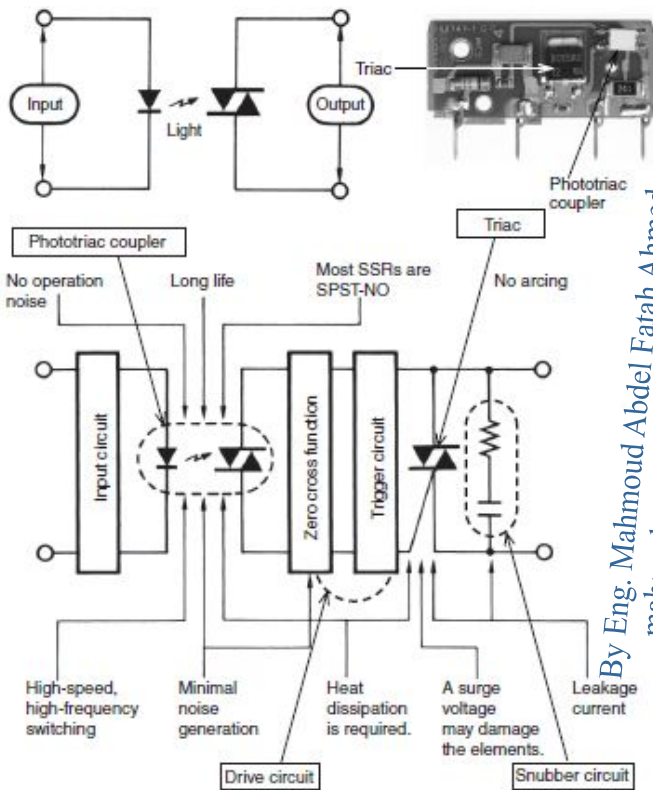
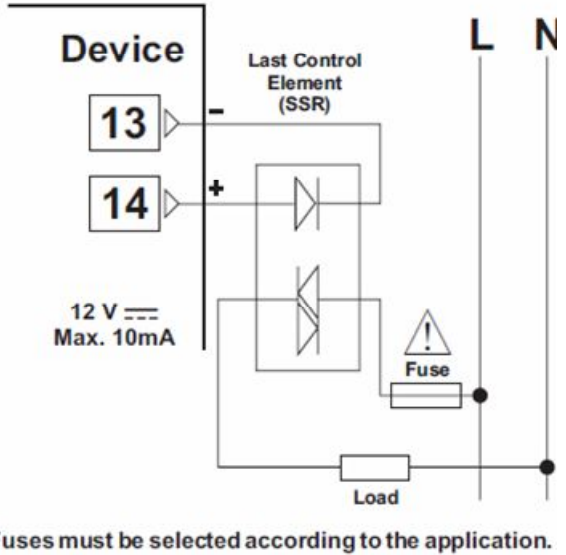
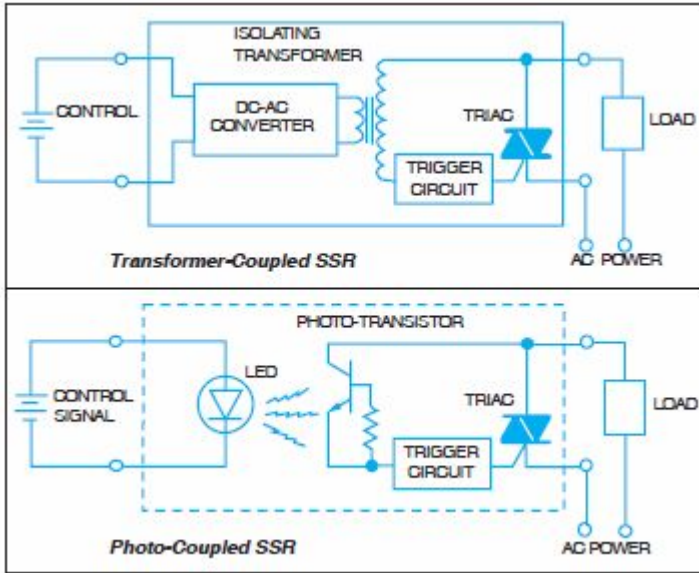

Solid State Relays ريلاي SSR

يوضح الجدول التالي شفرة ألوان الإزدواجات الحرارية وكذلك لون الغلاف الخارجي
 لأسلاك التمديد Extension Wire التي تصل الإزدواج الحرارى بأجهزة القياس
 Measuring Device

THERMOCOUPLE CHARACTERISTICS TABLE						
ANSI/ASTM	Symbol Single	Generic Names	Color Coding		Magnetic Yes/No	Environment (Bare Wire)
			Individual Conductor	Overall Jacket Extension Grade Wire		
T	TP TN	Copper Constantan, Nominal Composition: 55% Cu, 45% Ni	● Blue ● Red	● Blue	X X	Mild Oxidizing, Reducing. Vacuum or Inert. Good where moisture is present.
J	JP JN	Iron Constantan, Nominal Composition: 55% Cu, 45% Ni	○ White ● Red	● Black	X X	Reducing Vacuum, Inert. Limited use in oxidizing at High Temperatures. Not recommended for low temps.
E	EP EN	Chromel*, Nominal Composition: 90% Ni, 10% Cr Constantan, Nominal Composition: 55% Cu, 45% Ni	● Purple ● Red	● Purple	X X	Oxidizing or Inert. Limited use in Vacuum or Reducing.
K	KP KN	Chromel, Nominal Composition: 90% Ni, 10% Cr Alumel, Nominal Composition: 95% Ni, 2% Mn, 2% Al	● Yellow ● Red	● Yellow	X X	Clean Oxidizing and Inert. Limited use in Vacuum or Reducing
N	NP NN	Nicrosil*, Nominal Compositions: 84.6% Ni, 14.2% Cr, 1.4% Si Nisil*, Nominal Composition: 95.5% Ni, 4.4% Si, 1% Mg	● Orange ● Red	● Orange	X X	Clean Oxidizing and Inert. Limited use in Vacuum or Reducing
S	SP SN	Platinum 10% Rhodium Pure Platinum	● Black ● Red	● Green	X X	Oxidizing or Inert Atmospheres. Do not insert in metal tubes. Beware of contamination.
R	RP RN	Platinum 13% Rhodium Pure Platinum	● Black ● Red	● Green	X X	Oxidizing or Inert Atmospheres. Do not insert in metal tubes. Beware of contamination.
B	BP BN	Platinum 30% Rhodium Platinum 6% Rhodium	● Gray ● Red	● Gray	X X	Oxidizing or Inert Atmospheres. Do not insert in metal tubes. Beware of contamination.
W5* (C)	P N	Tungsten 5% Rhenium Tungsten 26% Rhenium	○ White/Red Trace ● Red	○ White/Red Trace	X X	Vacuum, Inert, Hydrogen Atmospheres. Beware of Embrittlement.
W3* (D)	P N	Tungsten 3% Rhenium Tungsten 25% Rhenium	○ White/Yellow Trace ● Red	○ White/Yellow Trace	X X	Vacuum, Inert, Hydrogen Atmospheres. Beware of Embrittlement.

* Conax designated, not ANSI/ASTM. ©Chromel-Alumel is a registered trademark of Hoskins Manufacturing. ©Nicrosil and Nisil are registered trademarks of Harrison Alloys, Inc.



By Eng. Mahmoud Abdel Fatah Ahmed
 mahmodcontrol@yahoo.com
 Mob. 01148695492

قياس الحرارة Temperature Measurement - شركة النفط السورية (مديرية حقول الحسكة - الرميلان)
 إعداد وتنفيذ / المهندس / محمود عبد الفتاح أحمد أبو الفتوح / المدرب المصرى للأجهزة الدقيقة

2009/2010

Mob. 01148695492

E.Mail mahmodcontrol@yahoo.com

معايرة الإزدواج الحرارى TC

قد يتعرض الإزدواج الحرارى TC إلى مشاكل (ظروف عمل قاسية أو غير مناسبة لنوعه) تؤدي إلى حدوث أخطاء Errors قياس تستدعى ضرورة إختباره للتأكد من صلاحيته .

و غالباً تكون مشاكل الـ TC مصدرها حدوث تآكل له وأكسده أو تغير فى التشكيل البنائى لمواد سلك الـ TC بسبب عوامل التآكل وتأثير عناصر خارجية كما فى الأفران الحرارية وغيرها .

At higher temperatures it is often better to use a heavier gauge of wire in order to maintain stability

**Thermocouple Calibrator
J, T, E, K, R, S, B, N, mV**

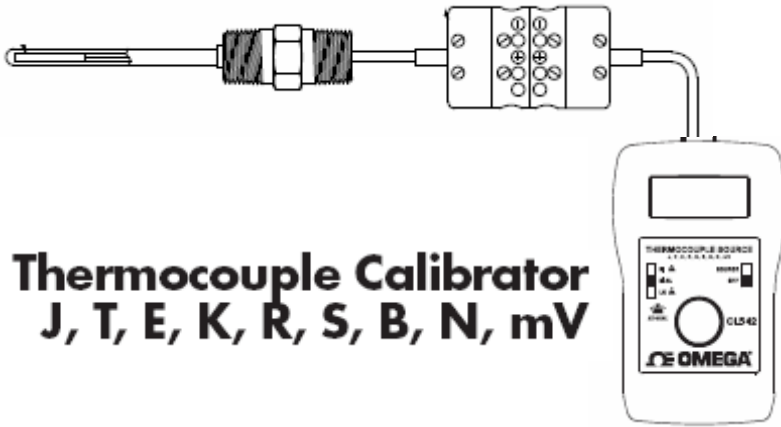

Shop online at

omega.com
omega.com
e-mail: info@omega.com
For latest product manuals:
omegamannual.info



**CL542
Thermocouple Calibrator
J, T, E, K, R, S, B, N, mV**

Severely corroded or oxidized thermocouples are always a possibility of trouble.

Changes in wire composition can result from corrosion and contamination by foreign elements.

Impurities such as sulfur and iron plus other factors picked up from furnace refractories, oxide scale, brazing alloys and fluxes constitute possible sources of drift away from initial calibration.

To check the working thermocouple, hook it to the test meter of known accuracy and observe the reading.

If the reading is the same as that previously obtained from the test thermocouple of known accuracy, then the working thermocouple is not the problem.

قبل المعايرة يجب علينا أن نحرص على القيام بالإختبارات الدورية للـ TC كل عام مرة أو مرتين ، وذلك حتى فى حالة عمل الـ TC بدون مشاكل .

يعتمد إستقرار عمل حساسات الإزدواج الحرارى (TC) على العوامل التالية :

- 1- مكان التركيب Installation Place
- 2- درجة الحرارة Temperature
- 3- البيئة Environment التى يعمل فيها الـ TC

الطريقة العامة للمعايرة (المقارنة Comparative Calibration) لإختبار الإزدواج الحرارى TC والمقاومة الحرارية RTD

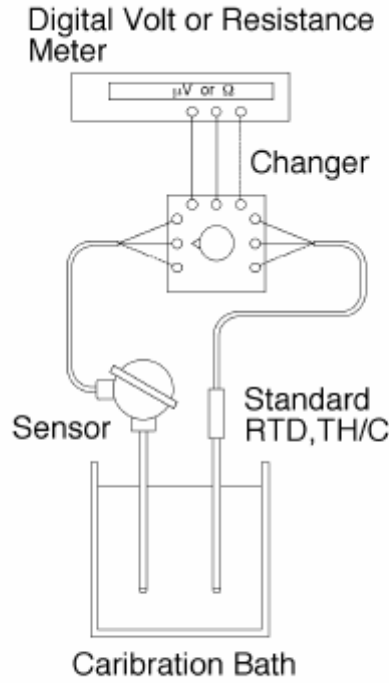

Eng. Mahmoud Abdel Fatah Ahmed
mahmodcontrol@yahoo.com
Mob. 01148695492

Comparative Calibration

– تتلخص الطريقة فى وضع **TC** أو **RTD** عيارى بجوار الآخر تحت الإختبار فى حمام تسخين خاص بالمعايرة **Calibration Bath**

– نرفع درجة الحرارة فى المدى الأكثر إستخداماً للـ **TC** أو **RTD**

– نقارن قراءات الحساس العيارى بالحساس تحت الإختبار وذلك بالإستعانة بجهاز أفوميتر لقياس الملى فولت الناتج من الـ **TC** ، وأيضا قياس المقاومة فى حالة الـ **RTD**

– إذا لم يكن هناك فرق فى القراءة أو يوجد فرق مسموح به يكون الحساس **TC** أو **RTD** سليم ، وإذا كان غير ذلك فإنه يجب تغييره بأخر جديد

تذكر المقولة المأثورة فى العمليات الإنتاجية وهى : إقتصادياً يكون إستبدال الـ TC بأخر جديد هو الإختيار المفضل على إختيار المخاطرة بفقد الإنتاجية أو الحصول على منتج غير دقيق أو قياسات حرارة غير دقيقة .

It is usually more economical to replace the thermocouple element than to risk loss of productivity, product or equipment through inaccurate temperature measurement.

إختيار مقاس سلك الإزدواج الحرارى Choosing Thermocouple Wire Gauge

عند قياس درجات الحرارة الأعلى باستخدام أى نوع من الـ TC فإنه يكون وغالباً من الأفضل استخدام مقاس سلك أكبر وذلك للحفاظ على إستمرار الحصول على قياسات مستقرة للحرارة

At higher temperatures it is often better to use a heavier gauge of wire in order to (below). Wire Gauge maintain stability (

The following table can be used as a very approximate guide to wire gauge:

Type	8 Gauge 4.06mm	16 Gauge 1.63mm	20 Gauge 0.91mm	24 Gauge 0.56mm	28 Gauge 0.38mm	30 Gauge 0.32mm
B	1820	-	-	1700	1700	-
C	2315	2315	2315	2315	2315	-
D	2315	2315	2315	2315	2000	-
E	870	620	540	430	400	370
G	2315	2315	2315	2315	2315	-
J	760	560	480	370	370	320
K	1260*	1000*	980	870	820	760
M	1260*	1200*	-	-	-	-
N	1260*	1000*	980	870	820	760
P	1395	-	1250	1250	1250	-
R	1760	-	-	1480	1480	-
S	1760	-	-	1480	1480	-
T	400	370	260	200	200	150

Eng. Mahmoud Abdel Fatah Ahmed
mahmodcontrol@yahoo.com
Mob. 01148695492

هذا الإختيار مهم جداً كما بالجدول لأنه يجب إختيار مقاس قطر السلك المناسب لدرجة الحرارة وكما ترى بالجدول فإن مقاس قطر السلك الأكبر يتحمل حرارة أعلى . وقد واجهت مشاكل تلف الإزدواجات الحرارية أو إنخفاض دقتها بسبب توريدها بمقاس أقل من المقاس الصحيح .

جداول العلاقة بين درجة الحرارة °C وإشارة الملى فولت mV المناظرة لها
للإزدواجات الحرارية TC

K^{°C}

TABLE 9 Type K Thermocouple — thermoelectric voltage as a function of temperature (°C); reference junctions at 0 °C

°C	0	1	2	3	4	5	6	7	8	9	10	°C
Thermoelectric Voltage in Millivolts												
-270	-6.458											-270
-260	-6.411	-6.444	-6.446	-6.448	-6.450	-6.452	-6.453	-6.455	-6.456	-6.457	-6.458	-260
-250	-6.404	-6.408	-6.413	-6.417	-6.421	-6.425	-6.429	-6.432	-6.435	-6.438	-6.441	-250
-240	-6.344	-6.351	-6.358	-6.364	-6.370	-6.377	-6.382	-6.388	-6.393	-6.399	-6.404	-240
-230	-6.262	-6.271	-6.280	-6.289	-6.297	-6.306	-6.314	-6.322	-6.329	-6.337	-6.344	-230
-220	-6.158	-6.170	-6.181	-6.192	-6.202	-6.213	-6.223	-6.233	-6.243	-6.252	-6.262	-220
-210	-6.035	-6.048	-6.061	-6.074	-6.087	-6.099	-6.111	-6.123	-6.135	-6.147	-6.158	-210
-200	-5.891	-5.907	-5.922	-5.936	-5.951	-5.965	-5.980	-5.994	-6.007	-6.021	-6.035	-200
-190	-5.730	-5.747	-5.763	-5.780	-5.797	-5.813	-5.829	-5.845	-5.861	-5.876	-5.891	-190
-180	-5.550	-5.569	-5.588	-5.606	-5.624	-5.642	-5.660	-5.678	-5.695	-5.713	-5.730	-180
-170	-5.354	-5.374	-5.395	-5.415	-5.435	-5.454	-5.474	-5.493	-5.512	-5.531	-5.550	-170
-160	-5.141	-5.163	-5.185	-5.207	-5.228	-5.250	-5.271	-5.292	-5.313	-5.333	-5.354	-160
-150	-4.913	-4.936	-4.960	-4.983	-5.006	-5.029	-5.052	-5.074	-5.097	-5.119	-5.141	-150
-140	-4.669	-4.694	-4.719	-4.744	-4.768	-4.793	-4.817	-4.841	-4.865	-4.889	-4.913	-140
-130	-4.411	-4.437	-4.463	-4.490	-4.516	-4.542	-4.567	-4.593	-4.618	-4.644	-4.669	-130
-120	-4.138	-4.166	-4.194	-4.221	-4.249	-4.276	-4.303	-4.330	-4.357	-4.384	-4.411	-120
-110	-3.852	-3.882	-3.911	-3.939	-3.968	-3.997	-4.025	-4.054	-4.082	-4.110	-4.138	-110
-100	-3.554	-3.584	-3.614	-3.645	-3.675	-3.705	-3.734	-3.764	-3.794	-3.823	-3.852	-100
-90	-3.243	-3.274	-3.306	-3.337	-3.368	-3.400	-3.431	-3.462	-3.492	-3.523	-3.554	-90
-80	-2.920	-2.953	-2.986	-3.018	-3.050	-3.083	-3.115	-3.147	-3.179	-3.211	-3.243	-80
-70	-2.587	-2.620	-2.654	-2.688	-2.721	-2.755	-2.788	-2.821	-2.854	-2.887	-2.920	-70
-60	-2.243	-2.278	-2.312	-2.347	-2.382	-2.416	-2.450	-2.485	-2.519	-2.553	-2.587	-60
-50	-1.889	-1.925	-1.961	-1.996	-2.032	-2.067	-2.103	-2.138	-2.173	-2.208	-2.243	-50
-40	-1.527	-1.564	-1.600	-1.637	-1.673	-1.709	-1.745	-1.782	-1.818	-1.854	-1.889	-40
-30	-1.156	-1.194	-1.231	-1.268	-1.305	-1.343	-1.380	-1.417	-1.453	-1.490	-1.527	-30
-20	-0.778	-0.816	-0.854	-0.892	-0.930	-0.968	-1.006	-1.043	-1.081	-1.119	-1.156	-20
-10	-0.392	-0.431	-0.470	-0.508	-0.547	-0.586	-0.624	-0.663	-0.701	-0.739	-0.778	-10
0	0.000	-0.039	-0.079	-0.118	-0.157	-0.197	-0.236	-0.275	-0.314	-0.353	-0.392	0
0	0.000	0.039	0.079	0.119	0.158	0.198	0.238	0.277	0.317	0.357	0.397	0
10	0.397	0.437	0.477	0.517	0.557	0.597	0.637	0.677	0.718	0.758	0.798	10
20	0.798	0.838	0.879	0.919	0.960	1.000	1.041	1.081	1.122	1.163	1.203	20
30	1.203	1.244	1.285	1.326	1.366	1.407	1.448	1.489	1.530	1.571	1.612	30
40	1.612	1.653	1.694	1.735	1.776	1.817	1.858	1.899	1.941	1.982	2.023	40
50	2.023	2.064	2.106	2.147	2.188	2.230	2.271	2.312	2.354	2.395	2.436	50
60	2.436	2.478	2.519	2.561	2.602	2.644	2.685	2.727	2.768	2.810	2.851	60
70	2.851	2.893	2.934	2.976	3.017	3.059	3.100	3.142	3.184	3.225	3.267	70
80	3.267	3.308	3.350	3.391	3.433	3.474	3.516	3.557	3.599	3.640	3.682	80
90	3.682	3.723	3.765	3.806	3.848	3.889	3.931	3.972	4.013	4.055	4.096	90
100	4.096	4.138	4.179	4.220	4.262	4.303	4.344	4.385	4.427	4.468	4.509	100
110	4.509	4.550	4.591	4.633	4.674	4.715	4.756	4.797	4.838	4.879	4.920	110
120	4.920	4.961	5.002	5.043	5.084	5.124	5.165	5.206	5.247	5.288	5.328	120
130	5.328	5.369	5.410	5.450	5.491	5.532	5.572	5.613	5.653	5.694	5.735	130
140	5.735	5.775	5.815	5.856	5.896	5.937	5.977	6.017	6.058	6.098	6.138	140
150	6.138	6.179	6.219	6.259	6.299	6.339	6.380	6.420	6.460	6.500	6.540	150
160	6.540	6.580	6.620	6.660	6.701	6.741	6.781	6.821	6.861	6.901	6.941	160
170	6.941	6.981	7.021	7.060	7.100	7.140	7.180	7.220	7.260	7.300	7.340	170
180	7.340	7.380	7.420	7.460	7.500	7.540	7.579	7.619	7.659	7.699	7.739	180
190	7.739	7.779	7.819	7.859	7.899	7.939	7.979	8.019	8.059	8.099	8.138	190

°C 0 1 2 3 4 5 6 7 8 9 10 °C

PyromATION®, INC.

30

TABLE 9 Type K Thermocouple — thermoelectric voltage as a function of temperature (°C); reference junctions at 0 °C

°C	0	1	2	3	4	5	6	7	8	9	10	°C
Thermoelectric Voltage in Millivolts												
200	8.138	8.178	8.218	8.258	8.298	8.338	8.378	8.418	8.458	8.499	8.539	200
210	8.539	8.579	8.619	8.659	8.699	8.739	8.779	8.819	8.860	8.900	8.940	210
220	8.940	8.980	9.020	9.061	9.101	9.141	9.181	9.222	9.262	9.302	9.343	220
230	9.343	9.383	9.423	9.464	9.504	9.545	9.585	9.626	9.666	9.707	9.747	230
240	9.747	9.788	9.828	9.869	9.909	9.950	9.991	10.031	10.072	10.113	10.153	240
250	10.153	10.194	10.235	10.276	10.316	10.357	10.398	10.439	10.480	10.520	10.561	250
260	10.561	10.602	10.643	10.684	10.725	10.766	10.807	10.848	10.889	10.930	10.971	260
270	10.971	11.012	11.053	11.094	11.135	11.176	11.217	11.259	11.300	11.341	11.382	270
280	11.382	11.423	11.465	11.506	11.547	11.588	11.630	11.671	11.712	11.753	11.795	280
290	11.795	11.836	11.877	11.919	11.960	12.001	12.043	12.084	12.126	12.167	12.209	290
300	12.209	12.250	12.291	12.333	12.374	12.416	12.457	12.499	12.540	12.582	12.624	300
310	12.624	12.665	12.707	12.748	12.790	12.831	12.873	12.915	12.956	12.998	13.040	310
320	13.040	13.081	13.123	13.165	13.206	13.248	13.290	13.331	13.373	13.415	13.457	320
330	13.457	13.498	13.540	13.582	13.624	13.665	13.707	13.749	13.791	13.833	13.874	330
340	13.874	13.916	13.958	14.000	14.042	14.084	14.126	14.167	14.209	14.251	14.293	340
350	14.293	14.335	14.377	14.419	14.461	14.503	14.545	14.587	14.629	14.671	14.713	350
360	14.713	14.755	14.797	14.839	14.881	14.923	14.965	15.007	15.049	15.091	15.133	360
370	15.133	15.175	15.217	15.259	15.301	15.343	15.385	15.427	15.469	15.511	15.554	370
380	15.554	15.596	15.638	15.680	15.722	15.764	15.806	15.848	15.891	15.933	15.975	380
390	15.975	16.017	16.059	16.102	16.144	16.186	16.228	16.270	16.313	16.355	16.397	390
400	16.397	16.439	16.482	16.524	16.566	16.608	16.651	16.693	16.735	16.778	16.820	400
410	16.820	16.862	16.904	16.947	16.989	17.031	17.074	17.116	17.158	17.201	17.243	410
420	17.243	17.285	17.328	17.370	17.413	17.455	17.497	17.540	17.582	17.624	17.667	420
430	17.667	17.709	17.752	17.794	17.837	17.879	17.921	17.964	18.006	18.049	18.091	430
440	18.091	18.134	18.176	18.218	18.261	18.303	18.346	18.388	18.431	18.473	18.516	440
450	18.516	18.558	18.601	18.643	18.686	18.728	18.771	18.813	18.856	18.898	18.941	450
460	18.941	18.983	19.026	19.068	19.111	19.154	19.196	19.239	19.281	19.324	19.366	460
470	19.366	19.409	19.451	19.494	19.537	19.579	19.622	19.664	19.707	19.750	19.792	470
480	19.792	19.835	19.877	19.920	19.962	20.005	20.048	20.090	20.133	20.175	20.218	480
490	20.218	20.261	20.303	20.346	20.389	20.431	20.474	20.516	20.559	20.602	20.644	490
500	20.644	20.687	20.730	20.772	20.815	20.857	20.900	20.943	20.985	21.028	21.071	500
510	21.071	21.113	21.156	21.199	21.241	21.284	21.326	21.369	21.412	21.454	21.497	510
520	21.497	21.540	21.582	21.625	21.668	21.710	21.753	21.796	21.838	21.881	21.924	520
530	21.924	21.966	22.009	22.052	22.094	22.137	22.179	22.222	22.265	22.307	22.350	530
540	22.350	22.393	22.435	22.478	22.521	22.563	22.606	22.649	22.691	22.734	22.776	540
550	22.776	22.819	22.862	22.904	22.947	22.990	23.032	23.075	23.117	23.160	23.203	550
560	23.203	23.245	23.288	23.331	23.373	23.416	23.458	23.501	23.544	23.586	23.629	560
570	23.629	23.671	23.714	23.757	23.799	23.842	23.884	23.927	23.970	24.012	24.055	570
580	24.055	24.097	24.140	24.182	24.225	24.267	24.310	24.353	24.395	24.438	24.480	580
590	24.480	24.523	24.565	24.608	24.650	24.693	24.735	24.778	24.820	24.863	24.905	590
600	24.905	24.948	24.990	25.033	25.075	25.118	25.160	25.203	25.245	25.288	25.330	600
610	25.330	25.373	25.415	25.458	25.500	25.543	25.585	25.627	25.670	25.712	25.755	610
620	25.755	25.797	25.840	25.882	25.924	25.967	26.009	26.052	26.094	26.136	26.179	620
630	26.179	26.221	26.263	26.306	26.348	26.390	26.433	26.475	26.517	26.560	26.602	630
640	26.602	26.644	26.687	26.729	26.771	26.814	26.856	26.898	26.940	26.983	27.025	640
650	27.025	27.067	27.109	27.152	27.194	27.236	27.278	27.320	27.363	27.405	27.447	650
660	27.447	27.489	27.531	27.574	27.616	27.658	27.700	27.742	27.784	27.826	27.869	660
670	27.869	27.911	27.953	27.995	28.037	28.079	28.121	28.163	28.205	28.247	28.289	670
680	28.289	28.332	28.374	28.416	28.458	28.500	28.542	28.584	28.626	28.668	28.710	680
690	28.710	28.752	28.794	28.835	28.877	28.919	28.961	29.003	29.045	29.087	29.129	690

K^oC

TABLE 9 Type K Thermocouple — thermoelectric voltage as a function of temperature (°C); reference junctions at 0 °C

°C	0	1	2	3	4	5	6	7	8	9	10	°C
Thermoelectric Voltage in Millivolts												
700	29.129	29.171	29.213	29.255	29.297	29.338	29.380	29.422	29.464	29.506	29.548	700
710	29.548	29.589	29.631	29.673	29.715	29.757	29.798	29.840	29.882	29.924	29.965	710
720	29.965	30.007	30.049	30.090	30.132	30.174	30.216	30.257	30.299	30.341	30.382	720
730	30.382	30.424	30.466	30.507	30.549	30.590	30.632	30.674	30.715	30.757	30.798	730
740	30.798	30.840	30.881	30.923	30.964	31.006	31.047	31.089	31.130	31.172	31.213	740
750	31.213	31.255	31.296	31.338	31.379	31.421	31.462	31.504	31.545	31.586	31.628	750
760	31.628	31.669	31.710	31.752	31.793	31.834	31.876	31.917	31.958	32.000	32.041	760
770	32.041	32.082	32.124	32.165	32.206	32.247	32.289	32.330	32.371	32.412	32.453	770
780	32.453	32.495	32.536	32.577	32.618	32.659	32.700	32.742	32.783	32.824	32.865	780
790	32.865	32.906	32.947	32.988	33.029	33.070	33.111	33.152	33.193	33.234	33.275	790
800	33.275	33.316	33.357	33.398	33.439	33.480	33.521	33.562	33.603	33.644	33.685	800
810	33.685	33.726	33.767	33.808	33.848	33.889	33.930	33.971	34.012	34.053	34.093	810
820	34.093	34.134	34.175	34.216	34.257	34.297	34.338	34.379	34.420	34.460	34.501	820
830	34.501	34.542	34.582	34.623	34.664	34.704	34.745	34.786	34.826	34.867	34.908	830
840	34.908	34.948	34.989	35.029	35.070	35.110	35.151	35.192	35.232	35.273	35.313	840
850	35.313	35.354	35.394	35.435	35.475	35.516	35.556	35.596	35.637	35.677	35.718	850
860	35.718	35.758	35.798	35.839	35.879	35.920	35.960	36.000	36.041	36.081	36.121	860
870	36.121	36.162	36.202	36.242	36.282	36.323	36.363	36.403	36.443	36.484	36.524	870
880	36.524	36.564	36.604	36.644	36.685	36.725	36.765	36.805	36.845	36.885	36.925	880
890	36.925	36.965	37.006	37.046	37.086	37.126	37.166	37.206	37.246	37.286	37.326	890
900	37.326	37.366	37.406	37.446	37.486	37.526	37.566	37.606	37.646	37.686	37.725	900
910	37.725	37.765	37.805	37.845	37.885	37.925	37.965	38.005	38.044	38.084	38.124	910
920	38.124	38.164	38.204	38.243	38.283	38.323	38.363	38.402	38.442	38.482	38.522	920
930	38.522	38.561	38.601	38.641	38.680	38.720	38.760	38.799	38.839	38.878	38.918	930
940	38.918	38.958	38.997	39.037	39.076	39.116	39.155	39.195	39.235	39.274	39.314	940
950	39.314	39.353	39.393	39.432	39.471	39.511	39.550	39.590	39.629	39.669	39.708	950
960	39.708	39.747	39.787	39.826	39.866	39.905	39.944	39.984	40.023	40.062	40.101	960
970	40.101	40.141	40.180	40.219	40.259	40.298	40.337	40.376	40.415	40.455	40.494	970
980	40.494	40.533	40.572	40.611	40.651	40.690	40.729	40.768	40.807	40.846	40.885	980
990	40.885	40.924	40.963	41.002	41.042	41.081	41.120	41.159	41.198	41.237	41.276	990
1000	41.276	41.315	41.354	41.393	41.431	41.470	41.509	41.548	41.587	41.626	41.665	1000
1010	41.665	41.704	41.743	41.781	41.820	41.859	41.898	41.937	41.976	42.014	42.053	1010
1020	42.053	42.092	42.131	42.169	42.208	42.247	42.286	42.324	42.363	42.402	42.440	1020
1030	42.440	42.479	42.518	42.556	42.595	42.633	42.672	42.711	42.749	42.788	42.826	1030
1040	42.826	42.865	42.903	42.942	42.980	43.019	43.057	43.096	43.134	43.173	43.211	1040
1050	43.211	43.250	43.288	43.327	43.365	43.403	43.442	43.480	43.518	43.557	43.595	1050
1060	43.595	43.633	43.672	43.710	43.748	43.787	43.825	43.863	43.901	43.940	43.978	1060
1070	43.978	44.016	44.054	44.092	44.130	44.169	44.207	44.245	44.283	44.321	44.359	1070
1080	44.359	44.397	44.435	44.473	44.512	44.550	44.588	44.626	44.664	44.702	44.740	1080
1090	44.740	44.778	44.816	44.853	44.891	44.929	44.967	45.005	45.043	45.081	45.119	1090
1100	45.119	45.157	45.194	45.232	45.270	45.308	45.346	45.383	45.421	45.459	45.497	1100
1110	45.497	45.534	45.572	45.610	45.647	45.685	45.723	45.760	45.798	45.836	45.873	1110
1120	45.873	45.911	45.948	45.986	46.024	46.061	46.099	46.136	46.174	46.211	46.249	1120
1130	46.249	46.286	46.324	46.361	46.398	46.436	46.473	46.511	46.548	46.585	46.623	1130
1140	46.623	46.660	46.697	46.735	46.772	46.809	46.847	46.884	46.921	46.958	46.995	1140
1150	46.995	47.033	47.070	47.107	47.144	47.181	47.218	47.256	47.293	47.330	47.367	1150
1160	47.367	47.404	47.441	47.478	47.515	47.552	47.589	47.626	47.663	47.700	47.737	1160
1170	47.737	47.774	47.811	47.848	47.884	47.921	47.958	47.995	48.032	48.069	48.105	1170
1180	48.105	48.142	48.179	48.216	48.252	48.289	48.326	48.363	48.399	48.436	48.473	1180
1190	48.473	48.509	48.546	48.582	48.619	48.656	48.692	48.729	48.765	48.802	48.838	1190

°C 0 1 2 3 4 5 6 7 8 9 10 °C

Pyromation®, INC.

شركة النظم السوربية (مديرية حقول الحسكة - الرميلة) Temperature Measurement
إعداد وتنفيذ / المهندس / محمود عبد الفتاح أحمد أبو الفتوح / المدرب المصري للأجهزة الدقيقة

K^{°C}**TABLE 9 Type K Thermocouple**— thermoelectric voltage as a function of temperature (°C); reference junctions at 0 °C

°C	0	1	2	3	4	5	6	7	8	9	10	°C
Thermoelectric Voltage in Millivolts												
1200	48.838	48.875	48.911	48.948	48.984	49.021	49.057	49.093	49.130	49.166	49.202	1200
1210	49.202	49.239	49.275	49.311	49.348	49.384	49.420	49.456	49.493	49.529	49.565	1210
1220	49.565	49.601	49.637	49.674	49.710	49.746	49.782	49.818	49.854	49.890	49.926	1220
1230	49.926	49.962	49.998	50.034	50.070	50.106	50.142	50.178	50.214	50.250	50.286	1230
1240	50.286	50.322	50.358	50.393	50.429	50.465	50.501	50.537	50.572	50.608	50.644	1240
1250	50.644	50.680	50.715	50.751	50.787	50.822	50.858	50.894	50.929	50.965	51.000	1250
1260	51.000	51.036	51.071	51.107	51.142	51.178	51.213	51.249	51.284	51.320	51.355	1260
1270	51.355	51.391	51.426	51.461	51.497	51.532	51.567	51.603	51.638	51.673	51.708	1270
1280	51.708	51.744	51.779	51.814	51.849	51.885	51.920	51.955	51.990	52.025	52.060	1280
1290	52.060	52.095	52.130	52.165	52.200	52.235	52.270	52.305	52.340	52.375	52.410	1290
1300	52.410	52.445	52.480	52.515	52.550	52.585	52.620	52.654	52.689	52.724	52.759	1300
1310	52.759	52.794	52.828	52.863	52.898	52.932	52.967	53.002	53.037	53.071	53.106	1310
1320	53.106	53.140	53.175	53.210	53.244	53.279	53.313	53.348	53.382	53.417	53.451	1320
1330	53.451	53.486	53.520	53.555	53.589	53.623	53.658	53.692	53.727	53.761	53.795	1330
1340	53.795	53.830	53.864	53.898	53.932	53.967	54.001	54.035	54.069	54.104	54.138	1340
1350	54.138	54.172	54.206	54.240	54.274	54.308	54.343	54.377	54.411	54.445	54.479	1350
1360	54.479	54.513	54.547	54.581	54.615	54.649	54.683	54.717	54.751	54.785	54.819	1360
1370	54.819	54.852	54.886									1370

TABLE 7 Type J Thermocouple—thermoelectric voltage as a function of temperature (°C); reference junctions at 0 °C

°C	0	1	2	3	4	5	6	7	8	9	10	°C
Thermoelectric Voltage in Millivolts												
-210	-8.095											-210
-200	-7.890	-7.912	-7.934	-7.955	-7.976	-7.996	-8.017	-8.037	-8.057	-8.076	-8.095	-200
-190	-7.659	-7.683	-7.707	-7.731	-7.755	-7.778	-7.801	-7.824	-7.846	-7.868	-7.890	-190
-180	-7.403	-7.429	-7.456	-7.482	-7.508	-7.534	-7.559	-7.585	-7.610	-7.634	-7.659	-180
-170	-7.123	-7.152	-7.181	-7.209	-7.237	-7.265	-7.293	-7.321	-7.348	-7.376	-7.403	-170
-160	-6.821	-6.853	-6.883	-6.914	-6.944	-6.975	-7.005	-7.035	-7.064	-7.094	-7.123	-160
-150	-6.500	-6.533	-6.566	-6.598	-6.631	-6.663	-6.695	-6.727	-6.759	-6.790	-6.821	-150
-140	-6.159	-6.194	-6.229	-6.263	-6.298	-6.332	-6.366	-6.400	-6.433	-6.467	-6.500	-140
-130	-5.801	-5.838	-5.874	-5.910	-5.946	-5.982	-6.018	-6.054	-6.089	-6.124	-6.159	-130
-120	-5.426	-5.465	-5.503	-5.541	-5.578	-5.616	-5.653	-5.690	-5.727	-5.764	-5.801	-120
-110	-5.037	-5.076	-5.116	-5.155	-5.194	-5.233	-5.272	-5.311	-5.350	-5.388	-5.426	-110
-100	-4.633	-4.674	-4.714	-4.755	-4.796	-4.836	-4.877	-4.917	-4.957	-4.997	-5.037	-100
-90	-4.215	-4.257	-4.300	-4.342	-4.384	-4.425	-4.467	-4.509	-4.550	-4.591	-4.633	-90
-80	-3.786	-3.829	-3.872	-3.916	-3.959	-4.002	-4.045	-4.088	-4.130	-4.173	-4.215	-80
-70	-3.344	-3.389	-3.434	-3.478	-3.522	-3.566	-3.610	-3.654	-3.698	-3.742	-3.786	-70
-60	-2.893	-2.938	-2.984	-3.029	-3.075	-3.120	-3.165	-3.210	-3.255	-3.300	-3.344	-60
-50	-2.431	-2.478	-2.524	-2.571	-2.617	-2.663	-2.709	-2.755	-2.801	-2.847	-2.893	-50
-40	-1.961	-2.008	-2.055	-2.103	-2.150	-2.197	-2.244	-2.291	-2.338	-2.385	-2.431	-40
-30	-1.482	-1.530	-1.578	-1.626	-1.674	-1.722	-1.770	-1.818	-1.865	-1.913	-1.961	-30
-20	-0.995	-1.044	-1.093	-1.142	-1.190	-1.239	-1.288	-1.336	-1.385	-1.433	-1.482	-20
-10	-0.501	-0.550	-0.600	-0.650	-0.699	-0.749	-0.798	-0.847	-0.896	-0.946	-0.995	-10
0	0.000	-0.050	-0.101	-0.151	-0.201	-0.251	-0.301	-0.351	-0.401	-0.451	-0.501	0
0	0.000	0.050	0.101	0.151	0.202	0.253	0.303	0.354	0.405	0.456	0.507	0
10	0.507	0.558	0.609	0.660	0.711	0.762	0.814	0.865	0.916	0.968	1.019	10
20	1.019	1.071	1.122	1.174	1.226	1.277	1.329	1.381	1.433	1.485	1.537	20
30	1.537	1.589	1.641	1.693	1.745	1.797	1.849	1.902	1.954	2.006	2.059	30
40	2.059	2.111	2.164	2.216	2.269	2.322	2.374	2.427	2.480	2.532	2.585	40
50	2.585	2.638	2.691	2.744	2.797	2.850	2.903	2.956	3.009	3.062	3.116	50
60	3.116	3.169	3.222	3.275	3.329	3.382	3.436	3.489	3.543	3.596	3.650	60
70	3.650	3.703	3.757	3.810	3.864	3.918	3.971	4.025	4.079	4.133	4.187	70
80	4.187	4.240	4.294	4.348	4.402	4.456	4.510	4.564	4.618	4.672	4.726	80
90	4.726	4.781	4.835	4.889	4.943	4.997	5.052	5.106	5.160	5.215	5.269	90
100	5.269	5.323	5.378	5.432	5.487	5.541	5.595	5.650	5.705	5.759	5.814	100
110	5.814	5.868	5.923	5.977	6.032	6.087	6.141	6.196	6.251	6.306	6.360	110
120	6.360	6.415	6.470	6.525	6.579	6.634	6.689	6.744	6.799	6.854	6.909	120
130	6.909	6.964	7.019	7.074	7.129	7.184	7.239	7.294	7.349	7.404	7.459	130
140	7.459	7.514	7.569	7.624	7.679	7.734	7.789	7.844	7.900	7.955	8.010	140
150	8.010	8.065	8.120	8.175	8.231	8.286	8.341	8.396	8.452	8.507	8.562	150
160	8.562	8.618	8.673	8.728	8.783	8.839	8.894	8.949	9.005	9.060	9.115	160
170	9.115	9.171	9.226	9.282	9.337	9.392	9.448	9.503	9.559	9.614	9.669	170
180	9.669	9.725	9.780	9.836	9.891	9.947	10.002	10.057	10.113	10.168	10.224	180
190	10.224	10.279	10.335	10.390	10.446	10.501	10.557	10.612	10.668	10.723	10.779	190
200	10.779	10.834	10.890	10.945	11.001	11.056	11.112	11.167	11.223	11.278	11.334	200
210	11.334	11.389	11.445	11.501	11.556	11.612	11.667	11.723	11.778	11.834	11.889	210
220	11.889	11.945	12.000	12.056	12.111	12.167	12.222	12.278	12.334	12.389	12.445	220
230	12.445	12.500	12.556	12.611	12.667	12.722	12.778	12.833	12.889	12.944	13.000	230
240	13.000	13.056	13.111	13.167	13.222	13.278	13.333	13.389	13.444	13.500	13.555	240

TABLE 7 Type J Thermocouple—thermoelectric voltage as a function of temperature (°C); reference junctions at 0 °C

°C	0	1	2	3	4	5	6	7	8	9	10	°C
Thermoelectric Voltage in Millivolts												
250	13.555	13.611	13.666	13.722	13.777	13.833	13.888	13.944	13.999	14.055	14.110	250
260	14.110	14.166	14.221	14.277	14.332	14.388	14.443	14.499	14.554	14.609	14.665	260
270	14.665	14.720	14.776	14.831	14.887	14.942	14.998	15.053	15.109	15.164	15.219	270
280	15.219	15.275	15.330	15.386	15.441	15.496	15.552	15.607	15.663	15.718	15.773	280
290	15.773	15.829	15.884	15.940	15.995	16.050	16.106	16.161	16.216	16.272	16.327	290
300	16.327	16.383	16.438	16.493	16.549	16.604	16.659	16.715	16.770	16.825	16.881	300
310	16.881	16.936	16.991	17.046	17.102	17.157	17.212	17.268	17.323	17.378	17.434	310
320	17.434	17.489	17.544	17.599	17.655	17.710	17.765	17.820	17.876	17.931	17.986	320
330	17.986	18.041	18.097	18.152	18.207	18.262	18.318	18.373	18.428	18.483	18.538	330
340	18.538	18.594	18.649	18.704	18.759	18.814	18.870	18.925	18.980	19.035	19.090	340
350	19.090	19.146	19.201	19.256	19.311	19.366	19.422	19.477	19.532	19.587	19.642	350
360	19.642	19.697	19.753	19.808	19.863	19.918	19.973	20.028	20.083	20.139	20.194	360
370	20.194	20.249	20.304	20.359	20.414	20.469	20.525	20.580	20.635	20.690	20.745	370
380	20.745	20.800	20.855	20.911	20.966	21.021	21.076	21.131	21.186	21.241	21.297	380
390	21.297	21.352	21.407	21.462	21.517	21.572	21.627	21.683	21.738	21.793	21.848	390
400	21.848	21.903	21.958	22.014	22.069	22.124	22.179	22.234	22.289	22.345	22.400	400
410	22.400	22.455	22.510	22.565	22.620	22.676	22.731	22.786	22.841	22.896	22.952	410
420	22.952	23.007	23.062	23.117	23.172	23.228	23.283	23.338	23.393	23.449	23.504	420
430	23.504	23.559	23.614	23.670	23.725	23.780	23.835	23.891	23.946	24.001	24.057	430
440	24.057	24.112	24.167	24.223	24.278	24.333	24.389	24.444	24.499	24.555	24.610	440
450	24.610	24.665	24.721	24.776	24.832	24.887	24.943	24.998	25.053	25.109	25.164	450
460	25.164	25.220	25.275	25.331	25.386	25.442	25.497	25.553	25.608	25.664	25.720	460
470	25.720	25.775	25.831	25.886	25.942	25.998	26.053	26.109	26.165	26.220	26.276	470
480	26.276	26.332	26.387	26.443	26.499	26.555	26.610	26.666	26.722	26.778	26.834	480
490	26.834	26.889	26.945	27.001	27.057	27.113	27.169	27.225	27.281	27.337	27.393	490
500	27.393	27.449	27.505	27.561	27.617	27.673	27.729	27.785	27.841	27.897	27.953	500
510	27.953	28.010	28.066	28.122	28.178	28.234	28.291	28.347	28.403	28.460	28.516	510
520	28.516	28.572	28.629	28.685	28.741	28.798	28.854	28.911	28.967	29.024	29.080	520
530	29.080	29.137	29.194	29.250	29.307	29.363	29.420	29.477	29.534	29.590	29.647	530
540	29.647	29.704	29.761	29.818	29.874	29.931	29.988	30.045	30.102	30.159	30.216	540
550	30.216	30.273	30.330	30.387	30.444	30.502	30.559	30.616	30.673	30.730	30.788	550
560	30.788	30.845	30.902	30.960	31.017	31.074	31.132	31.189	31.247	31.304	31.362	560
570	31.362	31.419	31.477	31.535	31.592	31.650	31.708	31.766	31.823	31.881	31.939	570
580	31.939	31.997	32.055	32.113	32.171	32.229	32.287	32.345	32.403	32.461	32.519	580
590	32.519	32.577	32.636	32.694	32.752	32.810	32.869	32.927	32.985	33.044	33.102	590
600	33.102	33.161	33.219	33.278	33.337	33.395	33.454	33.513	33.571	33.630	33.689	600
610	33.689	33.748	33.807	33.866	33.925	33.984	34.043	34.102	34.161	34.220	34.279	610
620	34.279	34.338	34.397	34.457	34.516	34.575	34.635	34.694	34.754	34.813	34.873	620
630	34.873	34.932	34.992	35.051	35.111	35.171	35.230	35.290	35.350	35.410	35.470	630
640	35.470	35.530	35.590	35.650	35.710	35.770	35.830	35.890	35.950	36.010	36.071	640
650	36.071	36.131	36.191	36.252	36.312	36.373	36.433	36.494	36.554	36.615	36.675	650
660	36.675	36.736	36.797	36.858	36.918	36.979	37.040	37.101	37.162	37.223	37.284	660
670	37.284	37.345	37.406	37.467	37.528	37.590	37.651	37.712	37.773	37.835	37.896	670
680	37.896	37.958	38.019	38.081	38.142	38.204	38.265	38.327	38.389	38.450	38.512	680
690	38.512	38.574	38.636	38.698	38.760	38.822	38.884	38.946	39.008	39.070	39.132	690
700	39.132	39.194	39.256	39.318	39.381	39.443	39.505	39.568	39.630	39.693	39.755	700
710	39.755	39.818	39.880	39.943	40.005	40.068	40.131	40.193	40.256	40.319	40.382	710
720	40.382	40.445	40.508	40.570	40.633	40.696	40.759	40.822	40.886	40.949	41.012	720
730	41.012	41.075	41.138	41.201	41.265	41.328	41.391	41.455	41.518	41.581	41.645	730
740	41.645	41.708	41.772	41.835	41.899	41.962	42.026	42.090	42.153	42.217	42.281	740
°C	0	1	2	3	4	5	6	7	8	9	10	°C

J^oC

TABLE 7 Type J Thermocouple — thermoelectric voltage as a function of temperature (°C); reference junctions at 0 °C

°C	0	1	2	3	4	5	6	7	8	9	10	°C
Thermoelectric Voltage in Millivolts												
250	13.555	13.611	13.666	13.722	13.777	13.833	13.888	13.944	13.999	14.055	14.110	250
260	14.110	14.166	14.221	14.277	14.332	14.388	14.443	14.499	14.554	14.609	14.665	260
270	14.665	14.720	14.776	14.831	14.887	14.942	14.998	15.053	15.109	15.164	15.219	270
280	15.219	15.275	15.330	15.386	15.441	15.496	15.552	15.607	15.663	15.718	15.773	280
290	15.773	15.829	15.884	15.940	15.995	16.050	16.106	16.161	16.216	16.272	16.327	290
300	16.327	16.383	16.438	16.493	16.549	16.604	16.659	16.715	16.770	16.825	16.881	300
310	16.881	16.936	16.991	17.046	17.102	17.157	17.212	17.268	17.323	17.378	17.434	310
320	17.434	17.489	17.544	17.599	17.655	17.710	17.765	17.820	17.876	17.931	17.986	320
330	17.986	18.041	18.097	18.152	18.207	18.262	18.318	18.373	18.428	18.483	18.538	330
340	18.538	18.594	18.649	18.704	18.759	18.814	18.870	18.925	18.980	19.035	19.090	340
350	19.090	19.146	19.201	19.256	19.311	19.366	19.422	19.477	19.532	19.587	19.642	350
360	19.642	19.697	19.753	19.808	19.863	19.918	19.973	20.028	20.083	20.139	20.194	360
370	20.194	20.249	20.304	20.359	20.414	20.469	20.525	20.580	20.635	20.690	20.745	370
380	20.745	20.800	20.855	20.911	20.966	21.021	21.076	21.131	21.186	21.241	21.297	380
390	21.297	21.352	21.407	21.462	21.517	21.572	21.627	21.683	21.738	21.793	21.848	390
400	21.848	21.903	21.958	22.014	22.069	22.124	22.179	22.234	22.289	22.345	22.400	400
410	22.400	22.455	22.510	22.565	22.620	22.676	22.731	22.786	22.841	22.896	22.952	410
420	22.952	23.007	23.062	23.117	23.172	23.228	23.283	23.338	23.393	23.449	23.504	420
430	23.504	23.559	23.614	23.670	23.725	23.780	23.835	23.891	23.946	24.001	24.057	430
440	24.057	24.112	24.167	24.223	24.278	24.333	24.389	24.444	24.499	24.555	24.610	440
450	24.610	24.665	24.721	24.776	24.832	24.887	24.943	24.998	25.053	25.109	25.164	450
460	25.164	25.220	25.275	25.331	25.386	25.442	25.497	25.553	25.608	25.664	25.720	460
470	25.720	25.775	25.831	25.886	25.942	25.998	26.053	26.109	26.165	26.220	26.276	470
480	26.276	26.332	26.387	26.443	26.499	26.555	26.610	26.666	26.722	26.778	26.834	480
490	26.834	26.889	26.945	27.001	27.057	27.113	27.169	27.225	27.281	27.337	27.393	490
500	27.393	27.449	27.505	27.561	27.617	27.673	27.729	27.785	27.841	27.897	27.953	500
510	27.953	28.010	28.066	28.122	28.178	28.234	28.291	28.347	28.403	28.460	28.516	510
520	28.516	28.572	28.629	28.685	28.741	28.798	28.854	28.911	28.967	29.024	29.080	520
530	29.080	29.137	29.194	29.250	29.307	29.363	29.420	29.477	29.534	29.590	29.647	530
540	29.647	29.704	29.761	29.818	29.874	29.931	29.988	30.045	30.102	30.159	30.216	540
550	30.216	30.273	30.330	30.387	30.444	30.502	30.559	30.616	30.673	30.730	30.788	550
560	30.788	30.845	30.902	30.960	31.017	31.074	31.132	31.189	31.247	31.304	31.362	560
570	31.362	31.419	31.477	31.535	31.592	31.650	31.708	31.766	31.823	31.881	31.939	570
580	31.939	31.997	32.055	32.113	32.171	32.229	32.287	32.345	32.403	32.461	32.519	580
590	32.519	32.577	32.636	32.694	32.752	32.810	32.869	32.927	32.985	33.044	33.102	590
600	33.102	33.161	33.219	33.278	33.337	33.395	33.454	33.513	33.571	33.630	33.689	600
610	33.689	33.748	33.807	33.866	33.925	33.984	34.043	34.102	34.161	34.220	34.279	610
620	34.279	34.338	34.397	34.457	34.516	34.575	34.635	34.694	34.754	34.813	34.873	620
630	34.873	34.932	34.992	35.051	35.111	35.171	35.230	35.290	35.350	35.410	35.470	630
640	35.470	35.530	35.590	35.650	35.710	35.770	35.830	35.890	35.950	36.010	36.071	640
650	36.071	36.131	36.191	36.252	36.312	36.373	36.433	36.494	36.554	36.615	36.675	650
660	36.675	36.736	36.797	36.858	36.918	36.979	37.040	37.101	37.162	37.223	37.284	660
670	37.284	37.345	37.406	37.467	37.528	37.590	37.651	37.712	37.773	37.835	37.896	670
680	37.896	37.958	38.019	38.081	38.142	38.204	38.265	38.327	38.389	38.450	38.512	680
690	38.512	38.574	38.636	38.698	38.760	38.822	38.884	38.946	39.008	39.070	39.132	690
700	39.132	39.194	39.256	39.318	39.381	39.443	39.505	39.568	39.630	39.693	39.755	700
710	39.755	39.818	39.880	39.943	40.005	40.068	40.131	40.193	40.256	40.319	40.382	710
720	40.382	40.445	40.508	40.570	40.633	40.696	40.759	40.822	40.886	40.949	41.012	720
730	41.012	41.075	41.138	41.201	41.265	41.328	41.391	41.455	41.518	41.581	41.645	730
740	41.645	41.708	41.772	41.835	41.899	41.962	42.026	42.090	42.153	42.217	42.281	740

Pyromation[®], INC.

Eng. Mahmoud Abdel Fatah Ahmed
E. Mail mahmodcontrol@yahoo.com

TABLE 7 Type J Thermocouple—thermoelectric voltage as a function of temperature (°C); reference junctions at 0 °C

°C	0	1	2	3	4	5	6	7	8	9	10	°C
Thermoelectric Voltage in Millivolts												
750	42.281	42.344	42.408	42.472	42.536	42.599	42.663	42.727	42.791	42.855	42.919	750
760	42.919	42.983	43.047	43.111	43.175	43.239	43.303	43.367	43.431	43.495	43.559	760
770	43.559	43.624	43.688	43.752	43.817	43.881	43.945	44.010	44.074	44.139	44.203	770
780	44.203	44.267	44.332	44.396	44.461	44.525	44.590	44.655	44.719	44.784	44.848	780
790	44.848	44.913	44.977	45.042	45.107	45.171	45.236	45.301	45.365	45.430	45.494	790
800	45.494	45.559	45.624	45.688	45.753	45.818	45.882	45.947	46.011	46.076	46.141	800
810	46.141	46.205	46.270	46.334	46.399	46.464	46.528	46.593	46.657	46.722	46.786	810
820	46.786	46.851	46.915	46.980	47.044	47.109	47.173	47.238	47.302	47.367	47.431	820
830	47.431	47.495	47.560	47.624	47.688	47.753	47.817	47.881	47.946	48.010	48.074	830
840	48.074	48.138	48.202	48.267	48.331	48.395	48.459	48.523	48.587	48.651	48.715	840
850	48.715	48.779	48.843	48.907	48.971	49.034	49.098	49.162	49.226	49.290	49.353	850
860	49.353	49.417	49.481	49.544	49.608	49.672	49.735	49.799	49.862	49.926	49.989	860
870	49.989	50.052	50.116	50.179	50.243	50.306	50.369	50.432	50.495	50.559	50.622	870
880	50.622	50.685	50.748	50.811	50.874	50.937	51.000	51.063	51.126	51.188	51.251	880
890	51.251	51.314	51.377	51.439	51.502	51.565	51.627	51.690	51.752	51.815	51.877	890
900	51.877	51.940	52.002	52.064	52.127	52.189	52.251	52.314	52.376	52.438	52.500	900
910	52.500	52.562	52.624	52.686	52.748	52.810	52.872	52.934	52.996	53.057	53.119	910
920	53.119	53.181	53.243	53.304	53.366	53.427	53.489	53.550	53.612	53.673	53.735	920
930	53.735	53.796	53.857	53.919	53.980	54.041	54.102	54.164	54.225	54.286	54.347	930
940	54.347	54.408	54.469	54.530	54.591	54.652	54.713	54.773	54.834	54.895	54.956	940
950	54.956	55.016	55.077	55.138	55.198	55.259	55.319	55.380	55.440	55.501	55.561	950
960	55.561	55.622	55.682	55.742	55.803	55.863	55.923	55.983	56.043	56.104	56.164	960
970	56.164	56.224	56.284	56.344	56.404	56.464	56.524	56.584	56.643	56.703	56.763	970
980	56.763	56.823	56.883	56.942	57.002	57.062	57.121	57.181	57.240	57.300	57.360	980
990	57.360	57.419	57.479	57.538	57.597	57.657	57.716	57.776	57.835	57.894	57.953	990
1000	57.953	58.013	58.072	58.131	58.190	58.249	58.309	58.368	58.427	58.486	58.545	1000
1010	58.545	58.604	58.663	58.722	58.781	58.840	58.899	58.957	59.016	59.075	59.134	1010
1020	59.134	59.193	59.252	59.310	59.369	59.428	59.487	59.545	59.604	59.663	59.721	1020
1030	59.721	59.780	59.838	59.897	59.956	60.014	60.073	60.131	60.190	60.248	60.307	1030
1040	60.307	60.365	60.423	60.482	60.540	60.599	60.657	60.715	60.774	60.832	60.890	1040
1050	60.890	60.949	61.007	61.065	61.123	61.182	61.240	61.298	61.356	61.415	61.473	1050
1060	61.473	61.531	61.589	61.647	61.705	61.763	61.822	61.880	61.938	61.996	62.054	1060
1070	62.054	62.112	62.170	62.228	62.286	62.344	62.402	62.460	62.518	62.576	62.634	1070
1080	62.634	62.692	62.750	62.808	62.866	62.924	62.982	63.040	63.098	63.156	63.214	1080
1090	63.214	63.271	63.329	63.387	63.445	63.503	63.561	63.619	63.677	63.734	63.792	1090
1100	63.792	63.850	63.908	63.966	64.024	64.081	64.139	64.197	64.255	64.313	64.370	1100
1110	64.370	64.428	64.486	64.544	64.602	64.659	64.717	64.775	64.833	64.890	64.948	1110
1120	64.948	65.006	65.064	65.121	65.179	65.237	65.295	65.352	65.410	65.468	65.525	1120
1130	65.525	65.583	65.641	65.699	65.756	65.814	65.872	65.929	65.987	66.045	66.102	1130
1140	66.102	66.160	66.218	66.275	66.333	66.391	66.448	66.506	66.564	66.621	66.679	1140
1150	66.679	66.737	66.794	66.852	66.910	66.967	67.025	67.082	67.140	67.198	67.255	1150
1160	67.255	67.313	67.370	67.428	67.486	67.543	67.601	67.658	67.716	67.773	67.831	1160
1170	67.831	67.888	67.946	68.003	68.061	68.119	68.176	68.234	68.291	68.348	68.406	1170
1180	68.406	68.463	68.521	68.578	68.636	68.693	68.751	68.808	68.865	68.923	68.980	1180
1190	68.980	69.037	69.095	69.152	69.209	69.267	69.324	69.381	69.439	69.496	69.553	1190
1200	69.553											1200
°C	0	1	2	3	4	5	6	7	8	9	10	°C

T°C

TABLE 17 Type T Thermocouple — thermoelectric voltage as a function of temperature (°C); reference junctions at 0 °C

°C	0	1	2	3	4	5	6	7	8	9	10	°C
Thermoelectric Voltage in Millivolts												
-270	-6.258											-270
-260	-6.232	-6.236	-6.239	-6.242	-6.245	-6.248	-6.251	-6.253	-6.255	-6.256	-6.258	-260
-250	-6.180	-6.187	-6.193	-6.198	-6.204	-6.209	-6.214	-6.219	-6.223	-6.228	-6.232	-250
-240	-6.105	-6.114	-6.122	-6.130	-6.138	-6.146	-6.153	-6.160	-6.167	-6.174	-6.180	-240
-230	-6.007	-6.017	-6.028	-6.038	-6.049	-6.059	-6.068	-6.078	-6.087	-6.096	-6.105	-230
-220	-5.888	-5.901	-5.914	-5.926	-5.938	-5.950	-5.962	-5.973	-5.985	-5.996	-6.007	-220
-210	-5.753	-5.767	-5.782	-5.795	-5.809	-5.823	-5.836	-5.850	-5.863	-5.876	-5.888	-210
-200	-5.603	-5.619	-5.634	-5.650	-5.665	-5.680	-5.695	-5.710	-5.724	-5.739	-5.753	-200
-190	-5.439	-5.456	-5.473	-5.489	-5.506	-5.523	-5.539	-5.555	-5.571	-5.587	-5.603	-190
-180	-5.261	-5.279	-5.297	-5.316	-5.334	-5.351	-5.369	-5.387	-5.404	-5.421	-5.439	-180
-170	-5.070	-5.089	-5.109	-5.128	-5.148	-5.167	-5.186	-5.205	-5.224	-5.242	-5.261	-170
-160	-4.865	-4.886	-4.907	-4.928	-4.949	-4.969	-4.989	-5.010	-5.030	-5.050	-5.070	-160
-150	-4.648	-4.671	-4.693	-4.715	-4.737	-4.759	-4.780	-4.802	-4.823	-4.844	-4.865	-150
-140	-4.419	-4.443	-4.466	-4.489	-4.512	-4.535	-4.558	-4.581	-4.604	-4.626	-4.648	-140
-130	-4.177	-4.202	-4.226	-4.251	-4.275	-4.300	-4.324	-4.348	-4.372	-4.395	-4.419	-130
-120	-3.923	-3.949	-3.975	-4.000	-4.026	-4.052	-4.077	-4.102	-4.127	-4.152	-4.177	-120
-110	-3.657	-3.684	-3.711	-3.738	-3.765	-3.791	-3.818	-3.844	-3.871	-3.897	-3.923	-110
-100	-3.379	-3.407	-3.435	-3.463	-3.491	-3.519	-3.547	-3.574	-3.602	-3.629	-3.657	-100
-90	-3.089	-3.118	-3.148	-3.177	-3.206	-3.235	-3.264	-3.293	-3.322	-3.350	-3.379	-90
-80	-2.788	-2.818	-2.849	-2.879	-2.910	-2.940	-2.970	-3.000	-3.030	-3.059	-3.089	-80
-70	-2.476	-2.507	-2.539	-2.571	-2.602	-2.633	-2.664	-2.695	-2.726	-2.757	-2.788	-70
-60	-2.153	-2.186	-2.218	-2.251	-2.283	-2.316	-2.348	-2.380	-2.412	-2.444	-2.476	-60
-50	-1.819	-1.853	-1.887	-1.920	-1.954	-1.987	-2.021	-2.054	-2.087	-2.120	-2.153	-50
-40	-1.475	-1.510	-1.545	-1.579	-1.614	-1.648	-1.683	-1.717	-1.751	-1.785	-1.819	-40
-30	-1.121	-1.157	-1.192	-1.228	-1.264	-1.299	-1.335	-1.370	-1.405	-1.440	-1.475	-30
-20	-0.757	-0.794	-0.830	-0.867	-0.904	-0.940	-0.976	-1.013	-1.049	-1.085	-1.121	-20
-10	-0.383	-0.421	-0.459	-0.496	-0.534	-0.571	-0.608	-0.646	-0.683	-0.720	-0.757	-10
0	0.000	-0.039	-0.077	-0.116	-0.154	-0.193	-0.231	-0.269	-0.307	-0.345	-0.383	0
0	0.000	0.039	0.078	0.117	0.156	0.195	0.234	0.273	0.312	0.352	0.391	0
10	0.391	0.431	0.470	0.510	0.549	0.589	0.629	0.669	0.709	0.749	0.790	10
20	0.790	0.830	0.870	0.911	0.951	0.992	1.033	1.074	1.114	1.155	1.196	20
30	1.196	1.238	1.279	1.320	1.362	1.403	1.445	1.486	1.528	1.570	1.612	30
40	1.612	1.654	1.696	1.738	1.780	1.823	1.865	1.908	1.950	1.993	2.036	40
50	2.036	2.079	2.122	2.165	2.208	2.251	2.294	2.338	2.381	2.425	2.468	50
60	2.468	2.512	2.556	2.600	2.643	2.687	2.732	2.776	2.820	2.864	2.909	60
70	2.909	2.953	2.998	3.043	3.087	3.132	3.177	3.222	3.267	3.312	3.358	70
80	3.358	3.403	3.448	3.494	3.539	3.585	3.631	3.677	3.722	3.768	3.814	80
90	3.814	3.860	3.907	3.953	3.999	4.046	4.092	4.138	4.185	4.232	4.279	90
100	4.279	4.325	4.372	4.419	4.466	4.513	4.561	4.608	4.655	4.702	4.750	100
110	4.750	4.798	4.845	4.893	4.941	4.988	5.036	5.084	5.132	5.180	5.228	110
120	5.228	5.277	5.325	5.373	5.422	5.470	5.519	5.567	5.616	5.665	5.714	120
130	5.714	5.763	5.812	5.861	5.910	5.959	6.008	6.057	6.107	6.156	6.206	130
140	6.206	6.255	6.305	6.355	6.404	6.454	6.504	6.554	6.604	6.654	6.704	140
150	6.704	6.754	6.805	6.855	6.905	6.956	7.006	7.057	7.107	7.158	7.209	150
160	7.209	7.260	7.310	7.361	7.412	7.463	7.515	7.566	7.617	7.668	7.720	160
170	7.720	7.771	7.823	7.874	7.926	7.977	8.029	8.081	8.133	8.185	8.237	170
180	8.237	8.289	8.341	8.393	8.445	8.497	8.550	8.602	8.654	8.707	8.759	180
190	8.759	8.812	8.865	8.917	8.970	9.023	9.076	9.129	9.182	9.235	9.288	190

°C 0 1 2 3 4 5 6 7 8 9 10 °C

Pyromation® INC.

T°C

TABLE 17 Type T Thermocouple — thermoelectric voltage as a function of temperature (°C); reference junctions at 0 °C

°C	0	1	2	3	4	5	6	7	8	9	10	°C
Thermoelectric Voltage in Millivolts												
200	9.288	9.341	9.395	9.448	9.501	9.555	9.608	9.662	9.715	9.769	9.822	200
210	9.822	9.876	9.930	9.984	10.038	10.092	10.146	10.200	10.254	10.308	10.362	210
220	10.362	10.417	10.471	10.525	10.580	10.634	10.689	10.743	10.798	10.853	10.907	220
230	10.907	10.962	11.017	11.072	11.127	11.182	11.237	11.292	11.347	11.403	11.458	230
240	11.458	11.513	11.569	11.624	11.680	11.735	11.791	11.846	11.902	11.958	12.013	240
250	12.013	12.069	12.125	12.181	12.237	12.293	12.349	12.405	12.461	12.518	12.574	250
260	12.574	12.630	12.687	12.743	12.799	12.856	12.912	12.969	13.026	13.082	13.139	260
270	13.139	13.196	13.253	13.310	13.366	13.423	13.480	13.537	13.595	13.652	13.709	270
280	13.709	13.766	13.823	13.881	13.938	13.995	14.053	14.110	14.168	14.226	14.283	280
290	14.283	14.341	14.399	14.456	14.514	14.572	14.630	14.688	14.746	14.804	14.862	290
300	14.862	14.920	14.978	15.036	15.095	15.153	15.211	15.270	15.328	15.386	15.445	300
310	15.445	15.503	15.562	15.621	15.679	15.738	15.797	15.856	15.914	15.973	16.032	310
320	16.032	16.091	16.150	16.209	16.268	16.327	16.387	16.446	16.505	16.564	16.624	320
330	16.624	16.683	16.742	16.802	16.861	16.921	16.980	17.040	17.100	17.159	17.219	330
340	17.219	17.279	17.339	17.399	17.458	17.518	17.578	17.638	17.698	17.759	17.819	340
350	17.819	17.879	17.939	17.999	18.060	18.120	18.180	18.241	18.301	18.362	18.422	350
360	18.422	18.483	18.543	18.604	18.665	18.725	18.786	18.847	18.908	18.969	19.030	360
370	19.030	19.091	19.152	19.213	19.274	19.335	19.396	19.457	19.518	19.579	19.641	370
380	19.641	19.702	19.763	19.825	19.886	19.947	20.009	20.070	20.132	20.193	20.255	380
390	20.255	20.317	20.378	20.440	20.502	20.563	20.625	20.687	20.748	20.810	20.872	390
400	20.872											400

R°C**TABLE 13 Type R Thermocouple—thermoelectric voltage as a function of temperature (°C); reference junctions at 0 °C**

°C	0	1	2	3	4	5	6	7	8	9	10	°C
Thermoelectric Voltage in Millivolts												
-50	-0.226											-50
-40	-0.188	-0.192	-0.196	-0.200	-0.204	-0.208	-0.211	-0.215	-0.219	-0.223	-0.226	-40
-30	-0.145	-0.150	-0.154	-0.158	-0.163	-0.167	-0.171	-0.175	-0.180	-0.184	-0.188	-30
-20	-0.100	-0.105	-0.109	-0.114	-0.119	-0.123	-0.128	-0.132	-0.137	-0.141	-0.145	-20
-10	-0.051	-0.056	-0.061	-0.066	-0.071	-0.076	-0.081	-0.086	-0.091	-0.095	-0.100	-10
0	0.000	-0.005	-0.011	-0.016	-0.021	-0.026	-0.031	-0.036	-0.041	-0.046	-0.051	0
0	0.000	0.005	0.011	0.016	0.021	0.027	0.032	0.038	0.043	0.049	0.054	0
10	0.054	0.060	0.065	0.071	0.077	0.082	0.088	0.094	0.100	0.105	0.111	10
20	0.111	0.117	0.123	0.129	0.135	0.141	0.147	0.153	0.159	0.165	0.171	20
30	0.171	0.177	0.183	0.189	0.195	0.201	0.207	0.214	0.220	0.226	0.232	30
40	0.232	0.239	0.245	0.251	0.258	0.264	0.271	0.277	0.284	0.290	0.296	40
50	0.296	0.303	0.310	0.316	0.323	0.329	0.336	0.343	0.349	0.356	0.363	50
60	0.363	0.369	0.376	0.383	0.390	0.397	0.403	0.410	0.417	0.424	0.431	60
70	0.431	0.438	0.445	0.452	0.459	0.466	0.473	0.480	0.487	0.494	0.501	70
80	0.501	0.508	0.516	0.523	0.530	0.537	0.544	0.552	0.559	0.566	0.573	80
90	0.573	0.581	0.588	0.595	0.603	0.610	0.618	0.625	0.632	0.640	0.647	90
100	0.647	0.655	0.662	0.670	0.677	0.685	0.693	0.700	0.708	0.715	0.723	100
110	0.723	0.731	0.738	0.746	0.754	0.761	0.769	0.777	0.785	0.792	0.800	110
120	0.800	0.808	0.816	0.824	0.832	0.839	0.847	0.855	0.863	0.871	0.879	120
130	0.879	0.887	0.895	0.903	0.911	0.919	0.927	0.935	0.943	0.951	0.959	130
140	0.959	0.967	0.976	0.984	0.992	1.000	1.008	1.016	1.025	1.033	1.041	140
150	1.041	1.049	1.058	1.066	1.074	1.082	1.091	1.099	1.107	1.116	1.124	150
160	1.124	1.132	1.141	1.149	1.158	1.166	1.175	1.183	1.191	1.200	1.208	160
170	1.208	1.217	1.225	1.234	1.242	1.251	1.260	1.268	1.277	1.285	1.294	170
180	1.294	1.303	1.311	1.320	1.329	1.337	1.346	1.355	1.363	1.372	1.381	180
190	1.381	1.389	1.398	1.407	1.416	1.425	1.433	1.442	1.451	1.460	1.469	190
200	1.469	1.477	1.486	1.495	1.504	1.513	1.522	1.531	1.540	1.549	1.558	200
210	1.558	1.567	1.575	1.584	1.593	1.602	1.611	1.620	1.629	1.639	1.648	210
220	1.648	1.657	1.666	1.675	1.684	1.693	1.702	1.711	1.720	1.729	1.739	220
230	1.739	1.748	1.757	1.766	1.775	1.784	1.794	1.803	1.812	1.821	1.831	230
240	1.831	1.840	1.849	1.858	1.868	1.877	1.886	1.895	1.905	1.914	1.923	240
250	1.923	1.933	1.942	1.951	1.961	1.970	1.980	1.989	1.998	2.008	2.017	250
260	2.017	2.027	2.036	2.046	2.055	2.064	2.074	2.083	2.093	2.102	2.112	260
270	2.112	2.121	2.131	2.140	2.150	2.159	2.169	2.179	2.188	2.198	2.207	270
280	2.207	2.217	2.226	2.236	2.246	2.255	2.265	2.275	2.284	2.294	2.304	280
290	2.304	2.313	2.323	2.333	2.342	2.352	2.362	2.371	2.381	2.391	2.401	290
300	2.401	2.410	2.420	2.430	2.440	2.449	2.459	2.469	2.479	2.488	2.498	300
310	2.498	2.508	2.518	2.528	2.538	2.547	2.557	2.567	2.577	2.587	2.597	310
320	2.597	2.607	2.617	2.626	2.636	2.646	2.656	2.666	2.676	2.686	2.696	320
330	2.696	2.706	2.716	2.726	2.736	2.746	2.756	2.766	2.776	2.786	2.796	330
340	2.796	2.806	2.816	2.826	2.836	2.846	2.856	2.866	2.876	2.886	2.896	340
350	2.896	2.906	2.916	2.926	2.937	2.947	2.957	2.967	2.977	2.987	2.997	350
360	2.997	3.007	3.018	3.028	3.038	3.048	3.058	3.068	3.079	3.089	3.099	360
370	3.099	3.109	3.119	3.130	3.140	3.150	3.160	3.171	3.181	3.191	3.201	370
380	3.201	3.212	3.222	3.232	3.242	3.253	3.263	3.273	3.284	3.294	3.304	380
390	3.304	3.315	3.325	3.335	3.346	3.356	3.366	3.377	3.387	3.397	3.408	390
°C	0	1	2	3	4	5	6	7	8	9	10	°C

Pyromation® ,INC.

50

TABLE 13 Type R Thermocouple — thermoelectric voltage as a function of temperature (°C); reference junctions at 0 °C

°C	0	1	2	3	4	5	6	7	8	9	10	°C
Thermoelectric Voltage in Millivolts												
400	3.408	3.418	3.428	3.439	3.449	3.460	3.470	3.480	3.491	3.501	3.512	400
410	3.512	3.522	3.533	3.543	3.553	3.564	3.574	3.585	3.595	3.606	3.616	410
420	3.616	3.627	3.637	3.648	3.658	3.669	3.679	3.690	3.700	3.711	3.721	420
430	3.721	3.732	3.742	3.753	3.764	3.774	3.785	3.795	3.806	3.816	3.827	430
440	3.827	3.838	3.848	3.859	3.869	3.880	3.891	3.901	3.912	3.922	3.933	440
450	3.933	3.944	3.954	3.965	3.976	3.986	3.997	4.008	4.018	4.029	4.040	450
460	4.040	4.050	4.061	4.072	4.083	4.093	4.104	4.115	4.125	4.136	4.147	460
470	4.147	4.158	4.168	4.179	4.190	4.201	4.211	4.222	4.233	4.244	4.255	470
480	4.255	4.265	4.276	4.287	4.298	4.309	4.319	4.330	4.341	4.352	4.363	480
490	4.363	4.373	4.384	4.395	4.406	4.417	4.428	4.439	4.449	4.460	4.471	490
500	4.471	4.482	4.493	4.504	4.515	4.526	4.537	4.548	4.558	4.569	4.580	500
510	4.580	4.591	4.602	4.613	4.624	4.635	4.646	4.657	4.668	4.679	4.690	510
520	4.690	4.701	4.712	4.723	4.734	4.745	4.756	4.767	4.778	4.789	4.800	520
530	4.800	4.811	4.822	4.833	4.844	4.855	4.866	4.877	4.888	4.899	4.910	530
540	4.910	4.922	4.933	4.944	4.955	4.966	4.977	4.988	4.999	5.010	5.021	540
550	5.021	5.033	5.044	5.055	5.066	5.077	5.088	5.099	5.111	5.122	5.133	550
560	5.133	5.144	5.155	5.166	5.178	5.189	5.200	5.211	5.222	5.234	5.245	560
570	5.245	5.256	5.267	5.279	5.290	5.301	5.312	5.323	5.335	5.346	5.357	570
580	5.357	5.369	5.380	5.391	5.402	5.414	5.425	5.436	5.448	5.459	5.470	580
590	5.470	5.481	5.493	5.504	5.515	5.527	5.538	5.549	5.561	5.572	5.583	590
600	5.583	5.595	5.606	5.618	5.629	5.640	5.652	5.663	5.674	5.686	5.697	600
610	5.697	5.709	5.720	5.731	5.743	5.754	5.766	5.777	5.789	5.800	5.812	610
620	5.812	5.823	5.834	5.846	5.857	5.869	5.880	5.892	5.903	5.915	5.926	620
630	5.926	5.938	5.949	5.961	5.972	5.984	5.995	6.007	6.018	6.030	6.041	630
640	6.041	6.053	6.065	6.076	6.088	6.099	6.111	6.122	6.134	6.146	6.157	640
650	6.157	6.169	6.180	6.192	6.204	6.215	6.227	6.238	6.250	6.262	6.273	650
660	6.273	6.285	6.297	6.308	6.320	6.332	6.343	6.355	6.367	6.378	6.390	660
670	6.390	6.402	6.413	6.425	6.437	6.448	6.460	6.472	6.484	6.495	6.507	670
680	6.507	6.519	6.531	6.542	6.554	6.566	6.578	6.589	6.601	6.613	6.625	680
690	6.625	6.636	6.648	6.660	6.672	6.684	6.695	6.707	6.719	6.731	6.743	690
700	6.743	6.755	6.766	6.778	6.790	6.802	6.814	6.826	6.838	6.849	6.861	700
710	6.861	6.873	6.885	6.897	6.909	6.921	6.933	6.945	6.956	6.968	6.980	710
720	6.980	6.992	7.004	7.016	7.028	7.040	7.052	7.064	7.076	7.088	7.100	720
730	7.100	7.112	7.124	7.136	7.148	7.160	7.172	7.184	7.196	7.208	7.220	730
740	7.220	7.232	7.244	7.256	7.268	7.280	7.292	7.304	7.316	7.328	7.340	740
750	7.340	7.352	7.364	7.376	7.389	7.401	7.413	7.425	7.437	7.449	7.461	750
760	7.461	7.473	7.485	7.498	7.510	7.522	7.534	7.546	7.558	7.570	7.583	760
770	7.583	7.595	7.607	7.619	7.631	7.644	7.656	7.668	7.680	7.692	7.705	770
780	7.705	7.717	7.729	7.741	7.753	7.766	7.778	7.790	7.802	7.815	7.827	780
790	7.827	7.839	7.851	7.864	7.876	7.888	7.901	7.913	7.925	7.938	7.950	790
800	7.950	7.962	7.974	7.987	7.999	8.011	8.024	8.036	8.048	8.061	8.073	800
810	8.073	8.086	8.098	8.110	8.123	8.135	8.147	8.160	8.172	8.185	8.197	810
820	8.197	8.209	8.222	8.234	8.247	8.259	8.272	8.284	8.296	8.309	8.321	820
830	8.321	8.334	8.346	8.359	8.371	8.384	8.396	8.409	8.421	8.434	8.446	830
840	8.446	8.459	8.471	8.484	8.496	8.509	8.521	8.534	8.546	8.559	8.571	840
850	8.571	8.584	8.597	8.609	8.622	8.634	8.647	8.659	8.672	8.685	8.697	850
860	8.697	8.710	8.722	8.735	8.748	8.760	8.773	8.785	8.798	8.811	8.823	860
870	8.823	8.836	8.849	8.861	8.874	8.887	8.899	8.912	8.925	8.937	8.950	870
880	8.950	8.963	8.975	8.988	9.001	9.014	9.026	9.039	9.052	9.065	9.077	880
890	9.077	9.090	9.103	9.115	9.128	9.141	9.154	9.167	9.179	9.192	9.205	890

R°C**TABLE 13 Type R Thermocouple — thermoelectric voltage as a function of temperature (°C); reference junctions at 0 °C**

°C	0	1	2	3	4	5	6	7	8	9	10	°C
Thermoelectric Voltage in Millivolts												
900	9.205	9.218	9.230	9.243	9.256	9.269	9.282	9.294	9.307	9.320	9.333	900
910	9.333	9.346	9.359	9.371	9.384	9.397	9.410	9.423	9.436	9.449	9.461	910
920	9.461	9.474	9.487	9.500	9.513	9.526	9.539	9.552	9.565	9.578	9.590	920
930	9.590	9.603	9.616	9.629	9.642	9.655	9.668	9.681	9.694	9.707	9.720	930
940	9.720	9.733	9.746	9.759	9.772	9.785	9.798	9.811	9.824	9.837	9.850	940
950	9.850	9.863	9.876	9.889	9.902	9.915	9.928	9.941	9.954	9.967	9.980	950
960	9.980	9.993	10.006	10.019	10.032	10.046	10.059	10.072	10.085	10.098	10.111	960
970	10.111	10.124	10.137	10.150	10.163	10.177	10.190	10.203	10.216	10.229	10.242	970
980	10.242	10.255	10.268	10.282	10.295	10.308	10.321	10.334	10.347	10.361	10.374	980
990	10.374	10.387	10.400	10.413	10.427	10.440	10.453	10.466	10.480	10.493	10.506	990
1000	10.506	10.519	10.532	10.546	10.559	10.572	10.585	10.599	10.612	10.625	10.638	1000
1010	10.638	10.652	10.665	10.678	10.692	10.705	10.718	10.731	10.745	10.758	10.771	1010
1020	10.771	10.785	10.798	10.811	10.825	10.838	10.851	10.865	10.878	10.891	10.905	1020
1030	10.905	10.918	10.932	10.945	10.958	10.972	10.985	10.998	11.012	11.025	11.039	1030
1040	11.039	11.052	11.065	11.079	11.092	11.106	11.119	11.132	11.146	11.159	11.173	1040
1050	11.173	11.186	11.200	11.213	11.227	11.240	11.253	11.267	11.280	11.294	11.307	1050
1060	11.307	11.321	11.334	11.348	11.361	11.375	11.388	11.402	11.415	11.429	11.442	1060
1070	11.442	11.456	11.469	11.483	11.496	11.510	11.524	11.537	11.551	11.564	11.578	1070
1080	11.578	11.591	11.605	11.618	11.632	11.646	11.659	11.673	11.686	11.700	11.714	1080
1090	11.714	11.727	11.741	11.754	11.768	11.782	11.795	11.809	11.822	11.836	11.850	1090
1100	11.850	11.863	11.877	11.891	11.904	11.918	11.931	11.945	11.959	11.972	11.986	1100
1110	11.986	12.000	12.013	12.027	12.041	12.054	12.068	12.082	12.096	12.109	12.123	1110
1120	12.123	12.137	12.150	12.164	12.178	12.191	12.205	12.219	12.233	12.246	12.260	1120
1130	12.260	12.274	12.288	12.301	12.315	12.329	12.342	12.356	12.370	12.384	12.397	1130
1140	12.397	12.411	12.425	12.439	12.453	12.466	12.480	12.494	12.508	12.521	12.535	1140
1150	12.535	12.549	12.563	12.577	12.590	12.604	12.618	12.632	12.646	12.659	12.673	1150
1160	12.673	12.687	12.701	12.715	12.729	12.742	12.756	12.770	12.784	12.798	12.812	1160
1170	12.812	12.825	12.839	12.853	12.867	12.881	12.895	12.909	12.922	12.936	12.950	1170
1180	12.950	12.964	12.978	12.992	13.006	13.019	13.033	13.047	13.061	13.075	13.089	1180
1190	13.089	13.103	13.117	13.131	13.145	13.158	13.172	13.186	13.200	13.214	13.228	1190
1200	13.228	13.242	13.256	13.270	13.284	13.298	13.311	13.325	13.339	13.353	13.367	1200
1210	13.367	13.381	13.395	13.409	13.423	13.437	13.451	13.465	13.479	13.493	13.507	1210
1220	13.507	13.521	13.535	13.549	13.563	13.577	13.590	13.604	13.618	13.632	13.646	1220
1230	13.646	13.660	13.674	13.688	13.702	13.716	13.730	13.744	13.758	13.772	13.786	1230
1240	13.786	13.800	13.814	13.828	13.842	13.856	13.870	13.884	13.898	13.912	13.926	1240
1250	13.926	13.940	13.954	13.968	13.982	13.996	14.010	14.024	14.038	14.052	14.066	1250
1260	14.066	14.081	14.095	14.109	14.123	14.137	14.151	14.165	14.179	14.193	14.207	1260
1270	14.207	14.221	14.235	14.249	14.263	14.277	14.291	14.305	14.319	14.333	14.347	1270
1280	14.347	14.361	14.375	14.390	14.404	14.418	14.432	14.446	14.460	14.474	14.488	1280
1290	14.488	14.502	14.516	14.530	14.544	14.558	14.572	14.586	14.601	14.615	14.629	1290
1300	14.629	14.643	14.657	14.671	14.685	14.699	14.713	14.727	14.741	14.755	14.770	1300
1310	14.770	14.784	14.798	14.812	14.826	14.840	14.854	14.868	14.882	14.896	14.911	1310
1320	14.911	14.925	14.939	14.953	14.967	14.981	14.995	15.009	15.023	15.037	15.052	1320
1330	15.052	15.066	15.080	15.094	15.108	15.122	15.136	15.150	15.164	15.179	15.193	1330
1340	15.193	15.207	15.221	15.235	15.249	15.263	15.277	15.291	15.306	15.320	15.334	1340
1350	15.334	15.348	15.362	15.376	15.390	15.404	15.419	15.433	15.447	15.461	15.475	1350
1360	15.475	15.489	15.503	15.517	15.531	15.546	15.560	15.574	15.588	15.602	15.616	1360
1370	15.616	15.630	15.645	15.659	15.673	15.687	15.701	15.715	15.729	15.743	15.758	1370
1380	15.758	15.772	15.786	15.800	15.814	15.828	15.842	15.856	15.871	15.885	15.899	1380
1390	15.899	15.913	15.927	15.941	15.955	15.969	15.984	15.998	16.012	16.026	16.040	1390
°C	0	1	2	3	4	5	6	7	8	9	10	°C

Pyromation®, INC.

52

قياس الحرارة Temperature Measurement - شركة النفط السورية (مديرية حقول الحسكة - الرميلان)
 إعداد وتنفيذ / المهندس / محمود عبد الفتاح أحمد أبو الفتوح / المدرب المصري للأجهزة الدقيقة

2009/2010

Mob. 01148695492

E.Mail mahmodcontrol@yahoo.com

TABLE 13 Type R Thermocouple—thermoelectric voltage as a function of temperature (°C); reference junctions at 0 °C

°C	0	1	2	3	4	5	6	7	8	9	10	°C
Thermoelectric Voltage in Millivolts												
1400	16.040	16.054	16.068	16.082	16.097	16.111	16.125	16.139	16.153	16.167	16.181	1400
1410	16.181	16.196	16.210	16.224	16.238	16.252	16.266	16.280	16.294	16.309	16.323	1410
1420	16.323	16.337	16.351	16.365	16.379	16.393	16.407	16.422	16.436	16.450	16.464	1420
1430	16.464	16.478	16.492	16.506	16.520	16.534	16.549	16.563	16.577	16.591	16.605	1430
1440	16.605	16.619	16.633	16.647	16.662	16.676	16.690	16.704	16.718	16.732	16.746	1440
1450	16.746	16.760	16.774	16.789	16.803	16.817	16.831	16.845	16.859	16.873	16.887	1450
1460	16.887	16.901	16.915	16.930	16.944	16.958	16.972	16.986	17.000	17.014	17.028	1460
1470	17.028	17.042	17.056	17.071	17.085	17.099	17.113	17.127	17.141	17.155	17.169	1470
1480	17.169	17.183	17.197	17.211	17.225	17.240	17.254	17.268	17.282	17.296	17.310	1480
1490	17.310	17.324	17.338	17.352	17.366	17.380	17.394	17.408	17.423	17.437	17.451	1490
1500	17.451	17.465	17.479	17.493	17.507	17.521	17.535	17.549	17.563	17.577	17.591	1500
1510	17.591	17.605	17.619	17.633	17.647	17.661	17.676	17.690	17.704	17.718	17.732	1510
1520	17.732	17.746	17.760	17.774	17.788	17.802	17.816	17.830	17.844	17.858	17.872	1520
1530	17.872	17.886	17.900	17.914	17.928	17.942	17.956	17.970	17.984	17.998	18.012	1530
1540	18.012	18.026	18.040	18.054	18.068	18.082	18.096	18.110	18.124	18.138	18.152	1540
1550	18.152	18.166	18.180	18.194	18.208	18.222	18.236	18.250	18.264	18.278	18.292	1550
1560	18.292	18.306	18.320	18.334	18.348	18.362	18.376	18.390	18.404	18.417	18.431	1560
1570	18.431	18.445	18.459	18.473	18.487	18.501	18.515	18.529	18.543	18.557	18.571	1570
1580	18.571	18.585	18.599	18.613	18.627	18.640	18.654	18.668	18.682	18.696	18.710	1580
1590	18.710	18.724	18.738	18.752	18.766	18.779	18.793	18.807	18.821	18.835	18.849	1590
1600	18.849	18.863	18.877	18.891	18.904	18.918	18.932	18.946	18.960	18.974	18.988	1600
1610	18.988	19.002	19.015	19.029	19.043	19.057	19.071	19.085	19.098	19.112	19.126	1610
1620	19.126	19.140	19.154	19.168	19.181	19.195	19.209	19.223	19.237	19.250	19.264	1620
1630	19.264	19.278	19.292	19.306	19.319	19.333	19.347	19.361	19.375	19.388	19.402	1630
1640	19.402	19.416	19.430	19.444	19.457	19.471	19.485	19.499	19.512	19.526	19.540	1640
1650	19.540	19.554	19.567	19.581	19.595	19.609	19.622	19.636	19.650	19.663	19.677	1650
1660	19.677	19.691	19.705	19.718	19.732	19.746	19.759	19.773	19.787	19.800	19.814	1660
1670	19.814	19.828	19.841	19.855	19.869	19.882	19.896	19.910	19.923	19.937	19.951	1670
1680	19.951	19.964	19.978	19.992	20.005	20.019	20.032	20.046	20.060	20.073	20.087	1680
1690	20.087	20.100	20.114	20.127	20.141	20.154	20.168	20.181	20.195	20.208	20.222	1690
1700	20.222	20.235	20.249	20.262	20.275	20.289	20.302	20.316	20.329	20.342	20.356	1700
1710	20.356	20.369	20.382	20.396	20.409	20.422	20.436	20.449	20.462	20.475	20.488	1710
1720	20.488	20.502	20.515	20.528	20.541	20.554	20.567	20.581	20.594	20.607	20.620	1720
1730	20.620	20.633	20.646	20.659	20.672	20.685	20.698	20.711	20.724	20.736	20.749	1730
1740	20.749	20.762	20.775	20.788	20.801	20.813	20.826	20.839	20.852	20.864	20.877	1740
1750	20.877	20.890	20.902	20.915	20.928	20.940	20.953	20.965	20.978	20.990	21.003	1750
1760	21.003	21.015	21.027	21.040	21.052	21.065	21.077	21.089	21.101			1760

TABLE 15 Type S Thermocouple—thermoelectric voltage as a function of temperature (°C); reference junctions at 0 °C

°C	0	1	2	3	4	5	6	7	8	9	10	°C
Thermoelectric Voltage in Millivolts												
-50	-0.236											-50
-40	-0.194	-0.199	-0.203	-0.207	-0.211	-0.215	-0.219	-0.224	-0.228	-0.232	-0.236	-40
-30	-0.150	-0.155	-0.159	-0.164	-0.168	-0.173	-0.177	-0.181	-0.186	-0.190	-0.194	-30
-20	-0.103	-0.108	-0.113	-0.117	-0.122	-0.127	-0.132	-0.136	-0.141	-0.146	-0.150	-20
-10	-0.053	-0.058	-0.063	-0.068	-0.073	-0.078	-0.083	-0.088	-0.093	-0.098	-0.103	-10
0	0.000	-0.005	-0.011	-0.016	-0.021	-0.027	-0.032	-0.037	-0.042	-0.048	-0.053	0
0	0.000	0.005	0.011	0.016	0.022	0.027	0.033	0.038	0.044	0.050	0.055	0
10	0.055	0.061	0.067	0.072	0.078	0.084	0.090	0.095	0.101	0.107	0.113	10
20	0.113	0.119	0.125	0.131	0.137	0.143	0.149	0.155	0.161	0.167	0.173	20
30	0.173	0.179	0.185	0.191	0.197	0.204	0.210	0.216	0.222	0.229	0.235	30
40	0.235	0.241	0.248	0.254	0.260	0.267	0.273	0.280	0.286	0.292	0.299	40
50	0.299	0.305	0.312	0.319	0.325	0.332	0.338	0.345	0.352	0.358	0.365	50
60	0.365	0.372	0.378	0.385	0.392	0.399	0.405	0.412	0.419	0.426	0.433	60
70	0.433	0.440	0.446	0.453	0.460	0.467	0.474	0.481	0.488	0.495	0.502	70
80	0.502	0.509	0.516	0.523	0.530	0.538	0.545	0.552	0.559	0.566	0.573	80
90	0.573	0.580	0.588	0.595	0.602	0.609	0.617	0.624	0.631	0.639	0.646	90
100	0.646	0.653	0.661	0.668	0.675	0.683	0.690	0.698	0.705	0.713	0.720	100
110	0.720	0.727	0.735	0.743	0.750	0.758	0.765	0.773	0.780	0.788	0.795	110
120	0.795	0.803	0.811	0.818	0.826	0.834	0.841	0.849	0.857	0.865	0.872	120
130	0.872	0.880	0.888	0.896	0.903	0.911	0.919	0.927	0.935	0.942	0.950	130
140	0.950	0.958	0.966	0.974	0.982	0.990	0.998	1.006	1.013	1.021	1.029	140
150	1.029	1.037	1.045	1.053	1.061	1.069	1.077	1.085	1.094	1.102	1.110	150
160	1.110	1.118	1.126	1.134	1.142	1.150	1.158	1.167	1.175	1.183	1.191	160
170	1.191	1.199	1.207	1.216	1.224	1.232	1.240	1.249	1.257	1.265	1.273	170
180	1.273	1.282	1.290	1.298	1.307	1.315	1.323	1.332	1.340	1.348	1.357	180
190	1.357	1.365	1.373	1.382	1.390	1.399	1.407	1.415	1.424	1.432	1.441	190
200	1.441	1.449	1.458	1.466	1.475	1.483	1.492	1.500	1.509	1.517	1.526	200
210	1.526	1.534	1.543	1.551	1.560	1.569	1.577	1.586	1.594	1.603	1.612	210
220	1.612	1.620	1.629	1.638	1.646	1.655	1.663	1.672	1.681	1.690	1.698	220
230	1.698	1.707	1.716	1.724	1.733	1.742	1.751	1.759	1.768	1.777	1.786	230
240	1.786	1.794	1.803	1.812	1.821	1.829	1.838	1.847	1.856	1.865	1.874	240
250	1.874	1.882	1.891	1.900	1.909	1.918	1.927	1.936	1.944	1.953	1.962	250
260	1.962	1.971	1.980	1.989	1.998	2.007	2.016	2.025	2.034	2.043	2.052	260
270	2.052	2.061	2.070	2.078	2.087	2.096	2.105	2.114	2.123	2.132	2.141	270
280	2.141	2.151	2.160	2.169	2.178	2.187	2.196	2.205	2.214	2.223	2.232	280
290	2.232	2.241	2.250	2.259	2.268	2.277	2.287	2.296	2.305	2.314	2.323	290
300	2.323	2.332	2.341	2.350	2.360	2.369	2.378	2.387	2.396	2.405	2.415	300
310	2.415	2.424	2.433	2.442	2.451	2.461	2.470	2.479	2.488	2.497	2.507	310
320	2.507	2.516	2.525	2.534	2.544	2.553	2.562	2.571	2.581	2.590	2.599	320
330	2.599	2.609	2.618	2.627	2.636	2.646	2.655	2.664	2.674	2.683	2.692	330
340	2.692	2.702	2.711	2.720	2.730	2.739	2.748	2.758	2.767	2.776	2.786	340
350	2.786	2.795	2.805	2.814	2.823	2.833	2.842	2.851	2.861	2.870	2.880	350
360	2.880	2.889	2.899	2.908	2.917	2.927	2.936	2.946	2.955	2.965	2.974	360
370	2.974	2.983	2.993	3.002	3.012	3.021	3.031	3.040	3.050	3.059	3.069	370
380	3.069	3.078	3.088	3.097	3.107	3.116	3.126	3.135	3.145	3.154	3.164	380
390	3.164	3.173	3.183	3.192	3.202	3.212	3.221	3.231	3.240	3.250	3.259	390
°C	0	1	2	3	4	5	6	7	8	9	10	°C



TABLE 15 Type S Thermocouple—thermoelectric voltage as a function of temperature (°C); reference junctions at 0 °C

°C	0	1	2	3	4	5	6	7	8	9	10	°C
Thermoelectric Voltage in Millivolts												
400	3.259	3.269	3.279	3.288	3.298	3.307	3.317	3.326	3.336	3.346	3.355	400
410	3.355	3.365	3.374	3.384	3.394	3.403	3.413	3.423	3.432	3.442	3.451	410
420	3.451	3.461	3.471	3.480	3.490	3.500	3.509	3.519	3.529	3.538	3.548	420
430	3.548	3.558	3.567	3.577	3.587	3.596	3.606	3.616	3.626	3.635	3.645	430
440	3.645	3.655	3.664	3.674	3.684	3.694	3.703	3.713	3.723	3.732	3.742	440
450	3.742	3.752	3.762	3.771	3.781	3.791	3.801	3.810	3.820	3.830	3.840	450
460	3.840	3.850	3.859	3.869	3.879	3.889	3.898	3.908	3.918	3.928	3.938	460
470	3.938	3.947	3.957	3.967	3.977	3.987	3.997	4.006	4.016	4.026	4.036	470
480	4.036	4.046	4.056	4.065	4.075	4.085	4.095	4.105	4.115	4.125	4.134	480
490	4.134	4.144	4.154	4.164	4.174	4.184	4.194	4.204	4.213	4.223	4.233	490
500	4.233	4.243	4.253	4.263	4.273	4.283	4.293	4.303	4.313	4.323	4.332	500
510	4.332	4.342	4.352	4.362	4.372	4.382	4.392	4.402	4.412	4.422	4.432	510
520	4.432	4.442	4.452	4.462	4.472	4.482	4.492	4.502	4.512	4.522	4.532	520
530	4.532	4.542	4.552	4.562	4.572	4.582	4.592	4.602	4.612	4.622	4.632	530
540	4.632	4.642	4.652	4.662	4.672	4.682	4.692	4.702	4.712	4.722	4.732	540
550	4.732	4.742	4.752	4.762	4.772	4.782	4.793	4.803	4.813	4.823	4.833	550
560	4.833	4.843	4.853	4.863	4.873	4.883	4.893	4.904	4.914	4.924	4.934	560
570	4.934	4.944	4.954	4.964	4.974	4.984	4.995	5.005	5.015	5.025	5.035	570
580	5.035	5.045	5.055	5.066	5.076	5.086	5.096	5.106	5.116	5.127	5.137	580
590	5.137	5.147	5.157	5.167	5.178	5.188	5.198	5.208	5.218	5.228	5.239	590
600	5.239	5.249	5.259	5.269	5.280	5.290	5.300	5.310	5.320	5.331	5.341	600
610	5.341	5.351	5.361	5.372	5.382	5.392	5.402	5.413	5.423	5.433	5.443	610
620	5.443	5.454	5.464	5.474	5.485	5.495	5.505	5.515	5.526	5.536	5.546	620
630	5.546	5.557	5.567	5.577	5.588	5.598	5.608	5.618	5.629	5.639	5.649	630
640	5.649	5.660	5.670	5.680	5.691	5.701	5.712	5.722	5.732	5.743	5.753	640
650	5.753	5.763	5.774	5.784	5.794	5.805	5.815	5.826	5.836	5.846	5.857	650
660	5.857	5.867	5.878	5.888	5.898	5.909	5.919	5.930	5.940	5.950	5.961	660
670	5.961	5.971	5.982	5.992	6.003	6.013	6.024	6.034	6.044	6.055	6.065	670
680	6.065	6.076	6.086	6.097	6.107	6.118	6.128	6.139	6.149	6.160	6.170	680
690	6.170	6.181	6.191	6.202	6.212	6.223	6.233	6.244	6.254	6.265	6.275	690
700	6.275	6.286	6.296	6.307	6.317	6.328	6.338	6.349	6.360	6.370	6.381	700
710	6.381	6.391	6.402	6.412	6.423	6.434	6.444	6.455	6.465	6.476	6.486	710
720	6.486	6.497	6.508	6.518	6.529	6.539	6.550	6.561	6.571	6.582	6.593	720
730	6.593	6.603	6.614	6.624	6.635	6.646	6.656	6.667	6.678	6.688	6.699	730
740	6.699	6.710	6.720	6.731	6.742	6.752	6.763	6.774	6.784	6.795	6.806	740
750	6.806	6.817	6.827	6.838	6.849	6.859	6.870	6.881	6.892	6.902	6.913	750
760	6.913	6.924	6.934	6.945	6.956	6.967	6.977	6.988	6.999	7.010	7.020	760
770	7.020	7.031	7.042	7.053	7.064	7.074	7.085	7.096	7.107	7.117	7.128	770
780	7.128	7.139	7.150	7.161	7.172	7.182	7.193	7.204	7.215	7.226	7.236	780
790	7.236	7.247	7.258	7.269	7.280	7.291	7.302	7.312	7.323	7.334	7.345	790
800	7.345	7.356	7.367	7.378	7.388	7.399	7.410	7.421	7.432	7.443	7.454	800
810	7.454	7.465	7.476	7.487	7.497	7.508	7.519	7.530	7.541	7.552	7.563	810
820	7.563	7.574	7.585	7.596	7.607	7.618	7.629	7.640	7.651	7.662	7.673	820
830	7.673	7.684	7.695	7.706	7.717	7.728	7.739	7.750	7.761	7.772	7.783	830
840	7.783	7.794	7.805	7.816	7.827	7.838	7.849	7.860	7.871	7.882	7.893	840
850	7.893	7.904	7.915	7.926	7.937	7.948	7.959	7.970	7.981	7.992	8.003	850
860	8.003	8.014	8.026	8.037	8.048	8.059	8.070	8.081	8.092	8.103	8.114	860
870	8.114	8.125	8.137	8.148	8.159	8.170	8.181	8.192	8.203	8.214	8.226	870
880	8.226	8.237	8.248	8.259	8.270	8.281	8.293	8.304	8.315	8.326	8.337	880
890	8.337	8.348	8.360	8.371	8.382	8.393	8.404	8.416	8.427	8.438	8.449	890

TABLE 15 Type S Thermocouple — thermoelectric voltage as a function of temperature (°C); reference junctions at 0 °C

°C	0	1	2	3	4	5	6	7	8	9	10	°C
Thermoelectric Voltage in Millivolts												
900	8.449	8.460	8.472	8.483	8.494	8.505	8.517	8.528	8.539	8.550	8.562	900
910	8.562	8.573	8.584	8.595	8.607	8.618	8.629	8.640	8.652	8.663	8.674	910
920	8.674	8.685	8.697	8.708	8.719	8.731	8.742	8.753	8.765	8.776	8.787	920
930	8.787	8.798	8.810	8.821	8.832	8.844	8.855	8.866	8.878	8.889	8.900	930
940	8.900	8.912	8.923	8.935	8.946	8.957	8.969	8.980	8.991	9.003	9.014	940
950	9.014	9.025	9.037	9.048	9.060	9.071	9.082	9.094	9.105	9.117	9.128	950
960	9.128	9.139	9.151	9.162	9.174	9.185	9.197	9.208	9.219	9.231	9.242	960
970	9.242	9.254	9.265	9.277	9.288	9.300	9.311	9.323	9.334	9.345	9.357	970
980	9.357	9.368	9.380	9.391	9.403	9.414	9.426	9.437	9.449	9.460	9.472	980
990	9.472	9.483	9.495	9.506	9.518	9.529	9.541	9.552	9.564	9.576	9.587	990
1000	9.587	9.599	9.610	9.622	9.633	9.645	9.656	9.668	9.680	9.691	9.703	1000
1010	9.703	9.714	9.726	9.737	9.749	9.761	9.772	9.784	9.795	9.807	9.819	1010
1020	9.819	9.830	9.842	9.853	9.865	9.877	9.888	9.900	9.911	9.923	9.935	1020
1030	9.935	9.946	9.958	9.970	9.981	9.993	10.005	10.016	10.028	10.040	10.051	1030
1040	10.051	10.063	10.075	10.086	10.098	10.110	10.121	10.133	10.145	10.156	10.168	1040
1050	10.168	10.180	10.191	10.203	10.215	10.227	10.238	10.250	10.262	10.273	10.285	1050
1060	10.285	10.297	10.309	10.320	10.332	10.344	10.356	10.367	10.379	10.391	10.403	1060
1070	10.403	10.414	10.426	10.438	10.450	10.461	10.473	10.485	10.497	10.509	10.520	1070
1080	10.520	10.532	10.544	10.556	10.567	10.579	10.591	10.603	10.615	10.626	10.638	1080
1090	10.638	10.650	10.662	10.674	10.686	10.697	10.709	10.721	10.733	10.745	10.757	1090
1100	10.757	10.768	10.780	10.792	10.804	10.816	10.828	10.839	10.851	10.863	10.875	1100
1110	10.875	10.887	10.899	10.911	10.922	10.934	10.946	10.958	10.970	10.982	10.994	1110
1120	10.994	11.006	11.017	11.029	11.041	11.053	11.065	11.077	11.089	11.101	11.113	1120
1130	11.113	11.125	11.136	11.148	11.160	11.172	11.184	11.196	11.208	11.220	11.232	1130
1140	11.232	11.244	11.256	11.268	11.280	11.291	11.303	11.315	11.327	11.339	11.351	1140
1150	11.351	11.363	11.375	11.387	11.399	11.411	11.423	11.435	11.447	11.459	11.471	1150
1160	11.471	11.483	11.495	11.507	11.519	11.531	11.542	11.554	11.566	11.578	11.590	1160
1170	11.590	11.602	11.614	11.626	11.638	11.650	11.662	11.674	11.686	11.698	11.710	1170
1180	11.710	11.722	11.734	11.746	11.758	11.770	11.782	11.794	11.806	11.818	11.830	1180
1190	11.830	11.842	11.854	11.866	11.878	11.890	11.902	11.914	11.926	11.939	11.951	1190
1200	11.951	11.963	11.975	11.987	11.999	12.011	12.023	12.035	12.047	12.059	12.071	1200
1210	12.071	12.083	12.095	12.107	12.119	12.131	12.143	12.155	12.167	12.179	12.191	1210
1220	12.191	12.203	12.216	12.228	12.240	12.252	12.264	12.276	12.288	12.300	12.312	1220
1230	12.312	12.324	12.336	12.348	12.360	12.372	12.384	12.397	12.409	12.421	12.433	1230
1240	12.433	12.445	12.457	12.469	12.481	12.493	12.505	12.517	12.529	12.542	12.554	1240
1250	12.554	12.566	12.578	12.590	12.602	12.614	12.626	12.638	12.650	12.662	12.675	1250
1260	12.675	12.687	12.699	12.711	12.723	12.735	12.747	12.759	12.771	12.783	12.796	1260
1270	12.796	12.808	12.820	12.832	12.844	12.856	12.868	12.880	12.892	12.905	12.917	1270
1280	12.917	12.929	12.941	12.953	12.965	12.977	12.989	13.001	13.014	13.026	13.038	1280
1290	13.038	13.050	13.062	13.074	13.086	13.098	13.111	13.123	13.135	13.147	13.159	1290
1300	13.159	13.171	13.183	13.195	13.208	13.220	13.232	13.244	13.256	13.268	13.280	1300
1310	13.280	13.292	13.305	13.317	13.329	13.341	13.353	13.365	13.377	13.390	13.402	1310
1320	13.402	13.414	13.426	13.438	13.450	13.462	13.474	13.487	13.499	13.511	13.523	1320
1330	13.523	13.535	13.547	13.559	13.572	13.584	13.596	13.608	13.620	13.632	13.644	1330
1340	13.644	13.657	13.669	13.681	13.693	13.705	13.717	13.729	13.742	13.754	13.766	1340
1350	13.766	13.778	13.790	13.802	13.814	13.826	13.839	13.851	13.863	13.875	13.887	1350
1360	13.887	13.899	13.911	13.924	13.936	13.948	13.960	13.972	13.984	13.996	14.009	1360
1370	14.009	14.021	14.033	14.045	14.057	14.069	14.081	14.094	14.106	14.118	14.130	1370
1380	14.130	14.142	14.154	14.166	14.178	14.191	14.203	14.215	14.227	14.239	14.251	1380
1390	14.251	14.263	14.276	14.288	14.300	14.312	14.324	14.336	14.348	14.360	14.373	1390
°C	0	1	2	3	4	5	6	7	8	9	10	°C

S°C

TABLE 15 Type S Thermocouple — thermoelectric voltage as a function of temperature (°C); reference junctions at 0 °C

°C	0	1	2	3	4	5	6	7	8	9	10	°C
Thermoelectric Voltage in Millivolts												
1400	14.373	14.385	14.397	14.409	14.421	14.433	14.445	14.457	14.470	14.482	14.494	1400
1410	14.494	14.506	14.518	14.530	14.542	14.554	14.567	14.579	14.591	14.603	14.615	1410
1420	14.615	14.627	14.639	14.651	14.664	14.676	14.688	14.700	14.712	14.724	14.736	1420
1430	14.736	14.748	14.760	14.773	14.785	14.797	14.809	14.821	14.833	14.845	14.857	1430
1440	14.857	14.869	14.881	14.894	14.906	14.918	14.930	14.942	14.954	14.966	14.978	1440
1450	14.978	14.990	15.002	15.015	15.027	15.039	15.051	15.063	15.075	15.087	15.099	1450
1460	15.099	15.111	15.123	15.135	15.148	15.160	15.172	15.184	15.196	15.208	15.220	1460
1470	15.220	15.232	15.244	15.256	15.268	15.280	15.292	15.304	15.317	15.329	15.341	1470
1480	15.341	15.353	15.365	15.377	15.389	15.401	15.413	15.425	15.437	15.449	15.461	1480
1490	15.461	15.473	15.485	15.497	15.509	15.521	15.534	15.546	15.558	15.570	15.582	1490
1500	15.582	15.594	15.606	15.618	15.630	15.642	15.654	15.666	15.678	15.690	15.702	1500
1510	15.702	15.714	15.726	15.738	15.750	15.762	15.774	15.786	15.798	15.810	15.822	1510
1520	15.822	15.834	15.846	15.858	15.870	15.882	15.894	15.906	15.918	15.930	15.942	1520
1530	15.942	15.954	15.966	15.978	15.990	16.002	16.014	16.026	16.038	16.050	16.062	1530
1540	16.062	16.074	16.086	16.098	16.110	16.122	16.134	16.146	16.158	16.170	16.182	1540
1550	16.182	16.194	16.205	16.217	16.229	16.241	16.253	16.265	16.277	16.289	16.301	1550
1560	16.301	16.313	16.325	16.337	16.349	16.361	16.373	16.385	16.396	16.408	16.420	1560
1570	16.420	16.432	16.444	16.456	16.468	16.480	16.492	16.504	16.516	16.527	16.539	1570
1580	16.539	16.551	16.563	16.575	16.587	16.599	16.611	16.623	16.634	16.646	16.658	1580
1590	16.658	16.670	16.682	16.694	16.706	16.718	16.729	16.741	16.753	16.765	16.777	1590
1600	16.777	16.789	16.801	16.812	16.824	16.836	16.848	16.860	16.872	16.883	16.895	1600
1610	16.895	16.907	16.919	16.931	16.943	16.954	16.966	16.978	16.990	17.002	17.013	1610
1620	17.013	17.025	17.037	17.049	17.061	17.072	17.084	17.096	17.108	17.120	17.131	1620
1630	17.131	17.143	17.155	17.167	17.178	17.190	17.202	17.214	17.225	17.237	17.249	1630
1640	17.249	17.261	17.272	17.284	17.296	17.308	17.319	17.331	17.343	17.355	17.366	1640
1650	17.366	17.378	17.390	17.401	17.413	17.425	17.437	17.448	17.460	17.472	17.483	1650
1660	17.483	17.495	17.507	17.518	17.530	17.542	17.553	17.565	17.577	17.588	17.600	1660
1670	17.600	17.612	17.623	17.635	17.647	17.658	17.670	17.682	17.693	17.705	17.717	1670
1680	17.717	17.728	17.740	17.751	17.763	17.775	17.786	17.798	17.809	17.821	17.832	1680
1690	17.832	17.844	17.855	17.867	17.878	17.890	17.901	17.913	17.924	17.936	17.947	1690
1700	17.947	17.959	17.970	17.982	17.993	18.004	18.016	18.027	18.039	18.050	18.061	1700
1710	18.061	18.073	18.084	18.095	18.107	18.118	18.129	18.140	18.152	18.163	18.174	1710
1720	18.174	18.185	18.196	18.208	18.219	18.230	18.241	18.252	18.263	18.274	18.285	1720
1730	18.285	18.297	18.308	18.319	18.330	18.341	18.352	18.362	18.373	18.384	18.395	1730
1740	18.395	18.406	18.417	18.428	18.439	18.449	18.460	18.471	18.482	18.493	18.503	1740
1750	18.503	18.514	18.525	18.535	18.546	18.557	18.567	18.578	18.588	18.599	18.609	1750
1760	18.609	18.620	18.630	18.641	18.651	18.661	18.672	18.682	18.693			1760

R°C**TABLE 13 Type R Thermocouple — thermoelectric voltage as a function of temperature (°C); reference junctions at 0 °C**

°C	0	1	2	3	4	5	6	7	8	9	10	°C
Thermoelectric Voltage in Millivolts												
-50	-0.226											-50
-40	-0.188	-0.192	-0.196	-0.200	-0.204	-0.208	-0.211	-0.215	-0.219	-0.223	-0.226	-40
-30	-0.145	-0.150	-0.154	-0.158	-0.163	-0.167	-0.171	-0.175	-0.180	-0.184	-0.188	-30
-20	-0.100	-0.105	-0.109	-0.114	-0.119	-0.123	-0.128	-0.132	-0.137	-0.141	-0.145	-20
-10	-0.051	-0.056	-0.061	-0.066	-0.071	-0.076	-0.081	-0.086	-0.091	-0.095	-0.100	-10
0	0.000	-0.005	-0.011	-0.016	-0.021	-0.026	-0.031	-0.036	-0.041	-0.046	-0.051	0
0	0.000	0.005	0.011	0.016	0.021	0.027	0.032	0.038	0.043	0.049	0.054	0
10	0.054	0.060	0.065	0.071	0.077	0.082	0.088	0.094	0.100	0.105	0.111	10
20	0.111	0.117	0.123	0.129	0.135	0.141	0.147	0.153	0.159	0.165	0.171	20
30	0.171	0.177	0.183	0.189	0.195	0.201	0.207	0.214	0.220	0.226	0.232	30
40	0.232	0.239	0.245	0.251	0.258	0.264	0.271	0.277	0.284	0.290	0.296	40
50	0.296	0.303	0.310	0.316	0.323	0.329	0.336	0.343	0.349	0.356	0.363	50
60	0.363	0.369	0.376	0.383	0.390	0.397	0.403	0.410	0.417	0.424	0.431	60
70	0.431	0.438	0.445	0.452	0.459	0.466	0.473	0.480	0.487	0.494	0.501	70
80	0.501	0.508	0.516	0.523	0.530	0.537	0.544	0.552	0.559	0.566	0.573	80
90	0.573	0.581	0.588	0.595	0.603	0.610	0.618	0.625	0.632	0.640	0.647	90
100	0.647	0.655	0.662	0.670	0.677	0.685	0.693	0.700	0.708	0.715	0.723	100
110	0.723	0.731	0.738	0.746	0.754	0.761	0.769	0.777	0.785	0.792	0.800	110
120	0.800	0.808	0.816	0.824	0.832	0.839	0.847	0.855	0.863	0.871	0.879	120
130	0.879	0.887	0.895	0.903	0.911	0.919	0.927	0.935	0.943	0.951	0.959	130
140	0.959	0.967	0.976	0.984	0.992	1.000	1.008	1.016	1.025	1.033	1.041	140
150	1.041	1.049	1.058	1.066	1.074	1.082	1.091	1.099	1.107	1.116	1.124	150
160	1.124	1.132	1.141	1.149	1.158	1.166	1.175	1.183	1.191	1.200	1.208	160
170	1.208	1.217	1.225	1.234	1.242	1.251	1.260	1.268	1.277	1.285	1.294	170
180	1.294	1.303	1.311	1.320	1.329	1.337	1.346	1.355	1.363	1.372	1.381	180
190	1.381	1.389	1.398	1.407	1.416	1.425	1.433	1.442	1.451	1.460	1.469	190
200	1.469	1.477	1.486	1.495	1.504	1.513	1.522	1.531	1.540	1.549	1.558	200
210	1.558	1.567	1.575	1.584	1.593	1.602	1.611	1.620	1.629	1.639	1.648	210
220	1.648	1.657	1.666	1.675	1.684	1.693	1.702	1.711	1.720	1.729	1.739	220
230	1.739	1.748	1.757	1.766	1.775	1.784	1.794	1.803	1.812	1.821	1.831	230
240	1.831	1.840	1.849	1.858	1.868	1.877	1.886	1.895	1.905	1.914	1.923	240
250	1.923	1.933	1.942	1.951	1.961	1.970	1.980	1.989	1.998	2.008	2.017	250
260	2.017	2.027	2.036	2.046	2.055	2.064	2.074	2.083	2.093	2.102	2.112	260
270	2.112	2.121	2.131	2.140	2.150	2.159	2.169	2.179	2.188	2.198	2.207	270
280	2.207	2.217	2.226	2.236	2.246	2.255	2.265	2.275	2.284	2.294	2.304	280
290	2.304	2.313	2.323	2.333	2.342	2.352	2.362	2.371	2.381	2.391	2.401	290
300	2.401	2.410	2.420	2.430	2.440	2.449	2.459	2.469	2.479	2.488	2.498	300
310	2.498	2.508	2.518	2.528	2.538	2.547	2.557	2.567	2.577	2.587	2.597	310
320	2.597	2.607	2.617	2.626	2.636	2.646	2.656	2.666	2.676	2.686	2.696	320
330	2.696	2.706	2.716	2.726	2.736	2.746	2.756	2.766	2.776	2.786	2.796	330
340	2.796	2.806	2.816	2.826	2.836	2.846	2.856	2.866	2.876	2.886	2.896	340
350	2.896	2.906	2.916	2.926	2.937	2.947	2.957	2.967	2.977	2.987	2.997	350
360	2.997	3.007	3.018	3.028	3.038	3.048	3.058	3.068	3.079	3.089	3.099	360
370	3.099	3.109	3.119	3.130	3.140	3.150	3.160	3.171	3.181	3.191	3.201	370
380	3.201	3.212	3.222	3.232	3.242	3.253	3.263	3.273	3.284	3.294	3.304	380
390	3.304	3.315	3.325	3.335	3.346	3.356	3.366	3.377	3.387	3.397	3.408	390
°C	0	1	2	3	4	5	6	7	8	9	10	°C

TABLE 13 Type R Thermocouple — thermoelectric voltage as a function of temperature (°C); reference junctions at 0 °C

°C	0	1	2	3	4	5	6	7	8	9	10	°C
Thermoelectric Voltage in Millivolts												
400	3.408	3.418	3.428	3.439	3.449	3.460	3.470	3.480	3.491	3.501	3.512	400
410	3.512	3.522	3.533	3.543	3.553	3.564	3.574	3.585	3.595	3.606	3.616	410
420	3.616	3.627	3.637	3.648	3.658	3.669	3.679	3.690	3.700	3.711	3.721	420
430	3.721	3.732	3.742	3.753	3.764	3.774	3.785	3.795	3.806	3.816	3.827	430
440	3.827	3.838	3.848	3.859	3.869	3.880	3.891	3.901	3.912	3.922	3.933	440
450	3.933	3.944	3.954	3.965	3.976	3.986	3.997	4.008	4.018	4.029	4.040	450
460	4.040	4.050	4.061	4.072	4.083	4.093	4.104	4.115	4.125	4.136	4.147	460
470	4.147	4.158	4.168	4.179	4.190	4.201	4.211	4.222	4.233	4.244	4.255	470
480	4.255	4.265	4.276	4.287	4.298	4.309	4.319	4.330	4.341	4.352	4.363	480
490	4.363	4.373	4.384	4.395	4.406	4.417	4.428	4.439	4.449	4.460	4.471	490
500	4.471	4.482	4.493	4.504	4.515	4.526	4.537	4.548	4.558	4.569	4.580	500
510	4.580	4.591	4.602	4.613	4.624	4.635	4.646	4.657	4.668	4.679	4.690	510
520	4.690	4.701	4.712	4.723	4.734	4.745	4.756	4.767	4.778	4.789	4.800	520
530	4.800	4.811	4.822	4.833	4.844	4.855	4.866	4.877	4.888	4.899	4.910	530
540	4.910	4.922	4.933	4.944	4.955	4.966	4.977	4.988	4.999	5.010	5.021	540
550	5.021	5.033	5.044	5.055	5.066	5.077	5.088	5.099	5.111	5.122	5.133	550
560	5.133	5.144	5.155	5.166	5.178	5.189	5.200	5.211	5.222	5.234	5.245	560
570	5.245	5.256	5.267	5.279	5.290	5.301	5.312	5.323	5.335	5.346	5.357	570
580	5.357	5.369	5.380	5.391	5.402	5.414	5.425	5.436	5.448	5.459	5.470	580
590	5.470	5.481	5.493	5.504	5.515	5.527	5.538	5.549	5.561	5.572	5.583	590
600	5.583	5.595	5.606	5.618	5.629	5.640	5.652	5.663	5.674	5.686	5.697	600
610	5.697	5.709	5.720	5.731	5.743	5.754	5.766	5.777	5.789	5.800	5.812	610
620	5.812	5.823	5.834	5.846	5.857	5.869	5.880	5.892	5.903	5.915	5.926	620
630	5.926	5.938	5.949	5.961	5.972	5.984	5.995	6.007	6.018	6.030	6.041	630
640	6.041	6.053	6.065	6.076	6.088	6.099	6.111	6.122	6.134	6.146	6.157	640
650	6.157	6.169	6.180	6.192	6.204	6.215	6.227	6.238	6.250	6.262	6.273	650
660	6.273	6.285	6.297	6.308	6.320	6.332	6.343	6.355	6.367	6.378	6.390	660
670	6.390	6.402	6.413	6.425	6.437	6.448	6.460	6.472	6.484	6.495	6.507	670
680	6.507	6.519	6.531	6.542	6.554	6.566	6.578	6.589	6.601	6.613	6.625	680
690	6.625	6.636	6.648	6.660	6.672	6.684	6.695	6.707	6.719	6.731	6.743	690
700	6.743	6.755	6.766	6.778	6.790	6.802	6.814	6.826	6.838	6.849	6.861	700
710	6.861	6.873	6.885	6.897	6.909	6.921	6.933	6.945	6.956	6.968	6.980	710
720	6.980	6.992	7.004	7.016	7.028	7.040	7.052	7.064	7.076	7.088	7.100	720
730	7.100	7.112	7.124	7.136	7.148	7.160	7.172	7.184	7.196	7.208	7.220	730
740	7.220	7.232	7.244	7.256	7.268	7.280	7.292	7.304	7.316	7.328	7.340	740
750	7.340	7.352	7.364	7.376	7.389	7.401	7.413	7.425	7.437	7.449	7.461	750
760	7.461	7.473	7.485	7.498	7.510	7.522	7.534	7.546	7.558	7.570	7.583	760
770	7.583	7.595	7.607	7.619	7.631	7.644	7.656	7.668	7.680	7.692	7.705	770
780	7.705	7.717	7.729	7.741	7.753	7.766	7.778	7.790	7.802	7.815	7.827	780
790	7.827	7.839	7.851	7.864	7.876	7.888	7.901	7.913	7.925	7.938	7.950	790
800	7.950	7.962	7.974	7.987	7.999	8.011	8.024	8.036	8.048	8.061	8.073	800
810	8.073	8.086	8.098	8.110	8.123	8.135	8.147	8.160	8.172	8.185	8.197	810
820	8.197	8.209	8.222	8.234	8.247	8.259	8.272	8.284	8.296	8.309	8.321	820
830	8.321	8.334	8.346	8.359	8.371	8.384	8.396	8.409	8.421	8.434	8.446	830
840	8.446	8.459	8.471	8.484	8.496	8.509	8.521	8.534	8.546	8.559	8.571	840
850	8.571	8.584	8.597	8.609	8.622	8.634	8.647	8.659	8.672	8.685	8.697	850
860	8.697	8.710	8.722	8.735	8.748	8.760	8.773	8.785	8.798	8.811	8.823	860
870	8.823	8.836	8.849	8.861	8.874	8.887	8.899	8.912	8.925	8.937	8.950	870
880	8.950	8.963	8.975	8.988	9.001	9.014	9.026	9.039	9.052	9.065	9.077	880
890	9.077	9.090	9.103	9.115	9.128	9.141	9.154	9.167	9.179	9.192	9.205	890
°C	0	1	2	3	4	5	6	7	8	9	10	°C

R^oC

TABLE 13 Type R Thermocouple — thermoelectric voltage as a function of temperature (°C); reference junctions at 0 °C

°C	0	1	2	3	4	5	6	7	8	9	10	°C
Thermoelectric Voltage in Millivolts												
900	9.205	9.218	9.230	9.243	9.256	9.269	9.282	9.294	9.307	9.320	9.333	900
910	9.333	9.346	9.359	9.371	9.384	9.397	9.410	9.423	9.436	9.449	9.461	910
920	9.461	9.474	9.487	9.500	9.513	9.526	9.539	9.552	9.565	9.578	9.590	920
930	9.590	9.603	9.616	9.629	9.642	9.655	9.668	9.681	9.694	9.707	9.720	930
940	9.720	9.733	9.746	9.759	9.772	9.785	9.798	9.811	9.824	9.837	9.850	940
950	9.850	9.863	9.876	9.889	9.902	9.915	9.928	9.941	9.954	9.967	9.980	950
960	9.980	9.993	10.006	10.019	10.032	10.046	10.059	10.072	10.085	10.098	10.111	960
970	10.111	10.124	10.137	10.150	10.163	10.177	10.190	10.203	10.216	10.229	10.242	970
980	10.242	10.255	10.268	10.282	10.295	10.308	10.321	10.334	10.347	10.361	10.374	980
990	10.374	10.387	10.400	10.413	10.427	10.440	10.453	10.466	10.480	10.493	10.506	990
1000	10.506	10.519	10.532	10.546	10.559	10.572	10.585	10.599	10.612	10.625	10.638	1000
1010	10.638	10.652	10.665	10.678	10.692	10.705	10.718	10.731	10.745	10.758	10.771	1010
1020	10.771	10.785	10.798	10.811	10.825	10.838	10.851	10.865	10.878	10.891	10.905	1020
1030	10.905	10.918	10.932	10.945	10.958	10.972	10.985	10.998	11.012	11.025	11.039	1030
1040	11.039	11.052	11.065	11.079	11.092	11.106	11.119	11.132	11.146	11.159	11.173	1040
1050	11.173	11.186	11.200	11.213	11.227	11.240	11.253	11.267	11.280	11.294	11.307	1050
1060	11.307	11.321	11.334	11.348	11.361	11.375	11.388	11.402	11.415	11.429	11.442	1060
1070	11.442	11.456	11.469	11.483	11.496	11.510	11.524	11.537	11.551	11.564	11.578	1070
1080	11.578	11.591	11.605	11.618	11.632	11.646	11.659	11.673	11.686	11.700	11.714	1080
1090	11.714	11.727	11.741	11.754	11.768	11.782	11.795	11.809	11.822	11.836	11.850	1090
1100	11.850	11.863	11.877	11.891	11.904	11.918	11.931	11.945	11.959	11.972	11.986	1100
1110	11.986	12.000	12.013	12.027	12.041	12.054	12.068	12.082	12.096	12.109	12.123	1110
1120	12.123	12.137	12.150	12.164	12.178	12.191	12.205	12.219	12.233	12.246	12.260	1120
1130	12.260	12.274	12.288	12.301	12.315	12.329	12.342	12.356	12.370	12.384	12.397	1130
1140	12.397	12.411	12.425	12.439	12.453	12.466	12.480	12.494	12.508	12.521	12.535	1140
1150	12.535	12.549	12.563	12.577	12.590	12.604	12.618	12.632	12.646	12.659	12.673	1150
1160	12.673	12.687	12.701	12.715	12.729	12.742	12.756	12.770	12.784	12.798	12.812	1160
1170	12.812	12.825	12.839	12.853	12.867	12.881	12.895	12.909	12.922	12.936	12.950	1170
1180	12.950	12.964	12.978	12.992	13.006	13.019	13.033	13.047	13.061	13.075	13.089	1180
1190	13.089	13.103	13.117	13.131	13.145	13.158	13.172	13.186	13.200	13.214	13.228	1190
1200	13.228	13.242	13.256	13.270	13.284	13.298	13.311	13.325	13.339	13.353	13.367	1200
1210	13.367	13.381	13.395	13.409	13.423	13.437	13.451	13.465	13.479	13.493	13.507	1210
1220	13.507	13.521	13.535	13.549	13.563	13.577	13.590	13.604	13.618	13.632	13.646	1220
1230	13.646	13.660	13.674	13.688	13.702	13.716	13.730	13.744	13.758	13.772	13.786	1230
1240	13.786	13.800	13.814	13.828	13.842	13.856	13.870	13.884	13.898	13.912	13.926	1240
1250	13.926	13.940	13.954	13.968	13.982	13.996	14.010	14.024	14.038	14.052	14.066	1250
1260	14.066	14.081	14.095	14.109	14.123	14.137	14.151	14.165	14.179	14.193	14.207	1260
1270	14.207	14.221	14.235	14.249	14.263	14.277	14.291	14.305	14.319	14.333	14.347	1270
1280	14.347	14.361	14.375	14.390	14.404	14.418	14.432	14.446	14.460	14.474	14.488	1280
1290	14.488	14.502	14.516	14.530	14.544	14.558	14.572	14.586	14.601	14.615	14.629	1290
1300	14.629	14.643	14.657	14.671	14.685	14.699	14.713	14.727	14.741	14.755	14.770	1300
1310	14.770	14.784	14.798	14.812	14.826	14.840	14.854	14.868	14.882	14.896	14.911	1310
1320	14.911	14.925	14.939	14.953	14.967	14.981	14.995	15.009	15.023	15.037	15.052	1320
1330	15.052	15.066	15.080	15.094	15.108	15.122	15.136	15.150	15.164	15.179	15.193	1330
1340	15.193	15.207	15.221	15.235	15.249	15.263	15.277	15.291	15.306	15.320	15.334	1340
1350	15.334	15.348	15.362	15.376	15.390	15.404	15.419	15.433	15.447	15.461	15.475	1350
1360	15.475	15.489	15.503	15.517	15.531	15.546	15.560	15.574	15.588	15.602	15.616	1360
1370	15.616	15.630	15.645	15.659	15.673	15.687	15.701	15.715	15.729	15.743	15.758	1370
1380	15.758	15.772	15.786	15.800	15.814	15.828	15.842	15.856	15.871	15.885	15.899	1380
1390	15.899	15.913	15.927	15.941	15.955	15.969	15.984	15.998	16.012	16.026	16.040	1390
°C	0	1	2	3	4	5	6	7	8	9	10	°C

TABLE 13 Type R Thermocouple — thermoelectric voltage as a function of temperature (°C); reference junctions at 0 °C

°C	0	1	2	3	4	5	6	7	8	9	10	°C
Thermoelectric Voltage in Millivolts												
1400	16.040	16.054	16.068	16.082	16.097	16.111	16.125	16.139	16.153	16.167	16.181	1400
1410	16.181	16.196	16.210	16.224	16.238	16.252	16.266	16.280	16.294	16.309	16.323	1410
1420	16.323	16.337	16.351	16.365	16.379	16.393	16.407	16.422	16.436	16.450	16.464	1420
1430	16.464	16.478	16.492	16.506	16.520	16.534	16.549	16.563	16.577	16.591	16.605	1430
1440	16.605	16.619	16.633	16.647	16.662	16.676	16.690	16.704	16.718	16.732	16.746	1440
1450	16.746	16.760	16.774	16.789	16.803	16.817	16.831	16.845	16.859	16.873	16.887	1450
1460	16.887	16.901	16.915	16.930	16.944	16.958	16.972	16.986	17.000	17.014	17.028	1460
1470	17.028	17.042	17.056	17.071	17.085	17.099	17.113	17.127	17.141	17.155	17.169	1470
1480	17.169	17.183	17.197	17.211	17.225	17.240	17.254	17.268	17.282	17.296	17.310	1480
1490	17.310	17.324	17.338	17.352	17.366	17.380	17.394	17.408	17.423	17.437	17.451	1490
1500	17.451	17.465	17.479	17.493	17.507	17.521	17.535	17.549	17.563	17.577	17.591	1500
1510	17.591	17.605	17.619	17.633	17.647	17.661	17.676	17.690	17.704	17.718	17.732	1510
1520	17.732	17.746	17.760	17.774	17.788	17.802	17.816	17.830	17.844	17.858	17.872	1520
1530	17.872	17.886	17.900	17.914	17.928	17.942	17.956	17.970	17.984	17.998	18.012	1530
1540	18.012	18.026	18.040	18.054	18.068	18.082	18.096	18.110	18.124	18.138	18.152	1540
1550	18.152	18.166	18.180	18.194	18.208	18.222	18.236	18.250	18.264	18.278	18.292	1550
1560	18.292	18.306	18.320	18.334	18.348	18.362	18.376	18.390	18.404	18.417	18.431	1560
1570	18.431	18.445	18.459	18.473	18.487	18.501	18.515	18.529	18.543	18.557	18.571	1570
1580	18.571	18.585	18.599	18.613	18.627	18.640	18.654	18.668	18.682	18.696	18.710	1580
1590	18.710	18.724	18.738	18.752	18.766	18.779	18.793	18.807	18.821	18.835	18.849	1590
1600	18.849	18.863	18.877	18.891	18.904	18.918	18.932	18.946	18.960	18.974	18.988	1600
1610	18.988	19.002	19.015	19.029	19.043	19.057	19.071	19.085	19.098	19.112	19.126	1610
1620	19.126	19.140	19.154	19.168	19.181	19.195	19.209	19.223	19.237	19.250	19.264	1620
1630	19.264	19.278	19.292	19.306	19.319	19.333	19.347	19.361	19.375	19.388	19.402	1630
1640	19.402	19.416	19.430	19.444	19.457	19.471	19.485	19.499	19.512	19.526	19.540	1640
1650	19.540	19.554	19.567	19.581	19.595	19.609	19.622	19.636	19.650	19.663	19.677	1650
1660	19.677	19.691	19.705	19.718	19.732	19.746	19.759	19.773	19.787	19.800	19.814	1660
1670	19.814	19.828	19.841	19.855	19.869	19.882	19.896	19.910	19.923	19.937	19.951	1670
1680	19.951	19.964	19.978	19.992	20.005	20.019	20.032	20.046	20.060	20.073	20.087	1680
1690	20.087	20.100	20.114	20.127	20.141	20.154	20.168	20.181	20.195	20.208	20.222	1690
1700	20.222	20.235	20.249	20.262	20.275	20.289	20.302	20.316	20.329	20.342	20.356	1700
1710	20.356	20.369	20.382	20.396	20.409	20.422	20.436	20.449	20.462	20.475	20.488	1710
1720	20.488	20.502	20.515	20.528	20.541	20.554	20.567	20.581	20.594	20.607	20.620	1720
1730	20.620	20.633	20.646	20.659	20.672	20.685	20.698	20.711	20.724	20.736	20.749	1730
1740	20.749	20.762	20.775	20.788	20.801	20.813	20.826	20.839	20.852	20.864	20.877	1740
1750	20.877	20.890	20.902	20.915	20.928	20.940	20.953	20.965	20.978	20.990	21.003	1750
1760	21.003	21.015	21.027	21.040	21.052	21.065	21.077	21.089	21.101			1760
°C	0	1	2	3	4	5	6	7	8	9	10	°C

E°C

TABLE 5 Type E Thermocouple — thermoelectric voltage as a function of temperature (°C); reference junctions at 0 °C

°C	0	1	2	3	4	5	6	7	8	9	10	°C
Thermoelectric Voltage in Millivolts												
-270	-9.835											-270
-260	-9.797	-9.802	-9.808	-9.813	-9.817	-9.821	-9.825	-9.828	-9.831	-9.833	-9.835	-260
-250	-9.718	-9.728	-9.737	-9.746	-9.754	-9.762	-9.770	-9.777	-9.784	-9.790	-9.797	-250
-240	-9.604	-9.617	-9.630	-9.642	-9.654	-9.666	-9.677	-9.688	-9.698	-9.709	-9.718	-240
-230	-9.455	-9.471	-9.487	-9.503	-9.519	-9.534	-9.548	-9.563	-9.577	-9.591	-9.604	-230
-220	-9.274	-9.293	-9.313	-9.331	-9.350	-9.368	-9.386	-9.404	-9.421	-9.438	-9.455	-220
-210	-9.063	-9.085	-9.107	-9.129	-9.151	-9.172	-9.193	-9.214	-9.234	-9.254	-9.274	-210
-200	-8.825	-8.850	-8.874	-8.899	-8.923	-8.947	-8.971	-8.994	-9.017	-9.040	-9.063	-200
-190	-8.561	-8.588	-8.616	-8.643	-8.669	-8.696	-8.722	-8.748	-8.774	-8.799	-8.825	-190
-180	-8.273	-8.303	-8.333	-8.362	-8.391	-8.420	-8.449	-8.477	-8.505	-8.533	-8.561	-180
-170	-7.963	-7.995	-8.027	-8.059	-8.090	-8.121	-8.152	-8.183	-8.213	-8.243	-8.273	-170
-160	-7.632	-7.666	-7.700	-7.733	-7.767	-7.800	-7.833	-7.866	-7.899	-7.931	-7.963	-160
-150	-7.279	-7.315	-7.351	-7.387	-7.423	-7.458	-7.493	-7.528	-7.563	-7.597	-7.632	-150
-140	-6.907	-6.945	-6.983	-7.021	-7.058	-7.096	-7.133	-7.170	-7.206	-7.243	-7.279	-140
-130	-6.516	-6.556	-6.596	-6.636	-6.675	-6.714	-6.753	-6.792	-6.831	-6.869	-6.907	-130
-120	-6.107	-6.149	-6.191	-6.232	-6.273	-6.314	-6.355	-6.396	-6.436	-6.476	-6.516	-120
-110	-5.681	-5.724	-5.767	-5.810	-5.853	-5.896	-5.939	-5.981	-6.023	-6.065	-6.107	-110
-100	-5.237	-5.282	-5.327	-5.372	-5.417	-5.461	-5.505	-5.549	-5.593	-5.637	-5.681	-100
-90	-4.777	-4.824	-4.871	-4.917	-4.963	-5.009	-5.055	-5.101	-5.147	-5.192	-5.237	-90
-80	-4.302	-4.350	-4.398	-4.446	-4.494	-4.542	-4.589	-4.636	-4.684	-4.731	-4.777	-80
-70	-3.811	-3.861	-3.911	-3.960	-4.009	-4.058	-4.107	-4.156	-4.205	-4.254	-4.302	-70
-60	-3.306	-3.357	-3.408	-3.459	-3.510	-3.561	-3.611	-3.661	-3.711	-3.761	-3.811	-60
-50	-2.787	-2.840	-2.892	-2.944	-2.996	-3.048	-3.100	-3.152	-3.204	-3.255	-3.306	-50
-40	-2.255	-2.309	-2.362	-2.416	-2.469	-2.523	-2.576	-2.629	-2.682	-2.735	-2.787	-40
-30	-1.709	-1.765	-1.820	-1.874	-1.929	-1.984	-2.038	-2.093	-2.147	-2.201	-2.255	-30
-20	-1.152	-1.208	-1.264	-1.320	-1.376	-1.432	-1.488	-1.543	-1.599	-1.654	-1.709	-20
-10	-0.582	-0.639	-0.697	-0.754	-0.811	-0.868	-0.925	-0.982	-1.039	-1.095	-1.152	-10
0	0.000	-0.059	-0.117	-0.176	-0.234	-0.292	-0.350	-0.408	-0.466	-0.524	-0.582	0
0	0.000	0.059	0.118	0.176	0.235	0.294	0.354	0.413	0.472	0.532	0.591	0
10	0.591	0.651	0.711	0.770	0.830	0.890	0.950	1.010	1.071	1.131	1.192	10
20	1.192	1.252	1.313	1.373	1.434	1.495	1.556	1.617	1.678	1.740	1.801	20
30	1.801	1.862	1.924	1.986	2.047	2.109	2.171	2.233	2.295	2.357	2.420	30
40	2.420	2.482	2.545	2.607	2.670	2.733	2.795	2.858	2.921	2.984	3.048	40
50	3.048	3.111	3.174	3.238	3.301	3.365	3.429	3.492	3.556	3.620	3.685	50
60	3.685	3.749	3.813	3.877	3.942	4.006	4.071	4.136	4.200	4.265	4.330	60
70	4.330	4.395	4.460	4.526	4.591	4.656	4.722	4.788	4.853	4.919	4.985	70
80	4.985	5.051	5.117	5.183	5.249	5.315	5.382	5.448	5.514	5.581	5.648	80
90	5.648	5.714	5.781	5.848	5.915	5.982	6.049	6.117	6.184	6.251	6.319	90
100	6.319	6.386	6.454	6.522	6.590	6.658	6.725	6.794	6.862	6.930	6.998	100
110	6.998	7.066	7.135	7.203	7.272	7.341	7.409	7.478	7.547	7.616	7.685	110
120	7.685	7.754	7.823	7.892	7.962	8.031	8.101	8.170	8.240	8.309	8.379	120
130	8.379	8.449	8.519	8.589	8.659	8.729	8.799	8.869	8.940	9.010	9.081	130
140	9.081	9.151	9.222	9.292	9.363	9.434	9.505	9.576	9.647	9.718	9.789	140
150	9.789	9.860	9.931	10.003	10.074	10.145	10.217	10.288	10.360	10.432	10.503	150
160	10.503	10.575	10.647	10.719	10.791	10.863	10.935	11.007	11.080	11.152	11.224	160
170	11.224	11.297	11.369	11.442	11.514	11.587	11.660	11.733	11.805	11.878	11.951	170
180	11.951	12.024	12.097	12.170	12.243	12.317	12.390	12.463	12.537	12.610	12.684	180
190	12.684	12.757	12.831	12.904	12.978	13.052	13.126	13.199	13.273	13.347	13.421	190
°C	0	1	2	3	4	5	6	7	8	9	10	°C

TABLE 5 Type E Thermocouple — thermoelectric voltage as a function of temperature (°C); reference junctions at 0 °C

°C	0	1	2	3	4	5	6	7	8	9	10	°C
Thermoelectric Voltage in Millivolts												
200	13.421	13.495	13.569	13.644	13.718	13.792	13.866	13.941	14.015	14.090	14.164	200
210	14.164	14.239	14.313	14.388	14.463	14.537	14.612	14.687	14.762	14.837	14.912	210
220	14.912	14.987	15.062	15.137	15.212	15.287	15.362	15.438	15.513	15.588	15.664	220
230	15.664	15.739	15.815	15.890	15.966	16.041	16.117	16.193	16.269	16.344	16.420	230
240	16.420	16.496	16.572	16.648	16.724	16.800	16.876	16.952	17.028	17.104	17.181	240
250	17.181	17.257	17.333	17.409	17.486	17.562	17.639	17.715	17.792	17.868	17.945	250
260	17.945	18.021	18.098	18.175	18.252	18.328	18.405	18.482	18.559	18.636	18.713	260
270	18.713	18.790	18.867	18.944	19.021	19.098	19.175	19.252	19.330	19.407	19.484	270
280	19.484	19.561	19.639	19.716	19.794	19.871	19.948	20.026	20.103	20.181	20.259	280
290	20.259	20.336	20.414	20.492	20.569	20.647	20.725	20.803	20.880	20.958	21.036	290
300	21.036	21.114	21.192	21.270	21.348	21.426	21.504	21.582	21.660	21.739	21.817	300
310	21.817	21.895	21.973	22.051	22.130	22.208	22.286	22.365	22.443	22.522	22.600	310
320	22.600	22.678	22.757	22.835	22.914	22.993	23.071	23.150	23.228	23.307	23.386	320
330	23.386	23.464	23.543	23.622	23.701	23.780	23.858	23.937	24.016	24.095	24.174	330
340	24.174	24.253	24.332	24.411	24.490	24.569	24.648	24.727	24.806	24.885	24.964	340
350	24.964	25.044	25.123	25.202	25.281	25.360	25.440	25.519	25.598	25.678	25.757	350
360	25.757	25.836	25.916	25.995	26.075	26.154	26.233	26.313	26.392	26.472	26.552	360
370	26.552	26.631	26.711	26.790	26.870	26.950	27.029	27.109	27.189	27.268	27.348	370
380	27.348	27.428	27.507	27.587	27.667	27.747	27.827	27.907	27.986	28.066	28.146	380
390	28.146	28.226	28.306	28.386	28.466	28.546	28.626	28.706	28.786	28.866	28.946	390
400	28.946	29.026	29.106	29.186	29.266	29.346	29.427	29.507	29.587	29.667	29.747	400
410	29.747	29.827	29.908	29.988	30.068	30.148	30.229	30.309	30.389	30.470	30.550	410
420	30.550	30.630	30.711	30.791	30.871	30.952	31.032	31.112	31.193	31.273	31.354	420
430	31.354	31.434	31.515	31.595	31.676	31.756	31.837	31.917	31.998	32.078	32.159	430
440	32.159	32.239	32.320	32.400	32.481	32.562	32.642	32.723	32.803	32.884	32.965	440
450	32.965	33.045	33.126	33.207	33.287	33.368	33.449	33.529	33.610	33.691	33.772	450
460	33.772	33.852	33.933	34.014	34.095	34.175	34.256	34.337	34.418	34.498	34.579	460
470	34.579	34.660	34.741	34.822	34.902	34.983	35.064	35.145	35.226	35.307	35.387	470
480	35.387	35.468	35.549	35.630	35.711	35.792	35.873	35.954	36.034	36.115	36.196	480
490	36.196	36.277	36.358	36.439	36.520	36.601	36.682	36.763	36.843	36.924	37.005	490
500	37.005	37.086	37.167	37.248	37.329	37.410	37.491	37.572	37.653	37.734	37.815	500
510	37.815	37.896	37.977	38.058	38.139	38.220	38.300	38.381	38.462	38.543	38.624	510
520	38.624	38.705	38.786	38.867	38.948	39.029	39.110	39.191	39.272	39.353	39.434	520
530	39.434	39.515	39.596	39.677	39.758	39.839	39.920	40.001	40.082	40.163	40.243	530
540	40.243	40.324	40.405	40.486	40.567	40.648	40.729	40.810	40.891	40.972	41.053	540
550	41.053	41.134	41.215	41.296	41.377	41.457	41.538	41.619	41.700	41.781	41.862	550
560	41.862	41.943	42.024	42.105	42.185	42.266	42.347	42.428	42.509	42.590	42.671	560
570	42.671	42.751	42.832	42.913	42.994	43.075	43.156	43.236	43.317	43.398	43.479	570
580	43.479	43.560	43.640	43.721	43.802	43.883	43.963	44.044	44.125	44.206	44.286	580
590	44.286	44.367	44.448	44.529	44.609	44.690	44.771	44.851	44.932	45.013	45.093	590
600	45.093	45.174	45.255	45.335	45.416	45.497	45.577	45.658	45.738	45.819	45.900	600
610	45.900	45.980	46.061	46.141	46.222	46.302	46.383	46.463	46.544	46.624	46.705	610
620	46.705	46.785	46.866	46.946	47.027	47.107	47.188	47.268	47.349	47.429	47.509	620
630	47.509	47.590	47.670	47.751	47.831	47.911	47.992	48.072	48.152	48.233	48.313	630
640	48.313	48.393	48.474	48.554	48.634	48.715	48.795	48.875	48.955	49.035	49.116	640
650	49.116	49.196	49.276	49.356	49.436	49.517	49.597	49.677	49.757	49.837	49.917	650
660	49.917	49.997	50.077	50.157	50.238	50.318	50.398	50.478	50.558	50.638	50.718	660
670	50.718	50.798	50.878	50.958	51.038	51.118	51.197	51.277	51.357	51.437	51.517	670
680	51.517	51.597	51.677	51.757	51.837	51.916	51.996	52.076	52.156	52.236	52.315	680
690	52.315	52.395	52.475	52.555	52.634	52.714	52.794	52.873	52.953	53.033	53.112	690
°C	0	1	2	3	4	5	6	7	8	9	10	°C

E°C

TABLE 5 Type E Thermocouple — thermoelectric voltage as a function of temperature (°C); reference junctions at 0 °C

°C	0	1	2	3	4	5	6	7	8	9	10	°C
Thermoelectric Voltage in Millivolts												
700	53.112	53.192	53.272	53.351	53.431	53.510	53.590	53.670	53.749	53.829	53.908	700
710	53.908	53.988	54.067	54.147	54.226	54.306	54.385	54.465	54.544	54.624	54.703	710
720	54.703	54.782	54.862	54.941	55.021	55.100	55.179	55.259	55.338	55.417	55.497	720
730	55.497	55.576	55.655	55.734	55.814	55.893	55.972	56.051	56.131	56.210	56.289	730
740	56.289	56.368	56.447	56.526	56.606	56.685	56.764	56.843	56.922	57.001	57.080	740
750	57.080	57.159	57.238	57.317	57.396	57.475	57.554	57.633	57.712	57.791	57.870	750
760	57.870	57.949	58.028	58.107	58.186	58.265	58.343	58.422	58.501	58.580	58.659	760
770	58.659	58.738	58.816	58.895	58.974	59.053	59.131	59.210	59.289	59.367	59.446	770
780	59.446	59.525	59.604	59.682	59.761	59.839	59.918	59.997	60.075	60.154	60.232	780
790	60.232	60.311	60.390	60.468	60.547	60.625	60.704	60.782	60.860	60.939	61.017	790
800	61.017	61.096	61.174	61.253	61.331	61.409	61.488	61.566	61.644	61.723	61.801	800
810	61.801	61.879	61.958	62.036	62.114	62.192	62.271	62.349	62.427	62.505	62.583	810
820	62.583	62.662	62.740	62.818	62.896	62.974	63.052	63.130	63.208	63.286	63.364	820
830	63.364	63.442	63.520	63.598	63.676	63.754	63.832	63.910	63.988	64.066	64.144	830
840	64.144	64.222	64.300	64.377	64.455	64.533	64.611	64.689	64.766	64.844	64.922	840
850	64.922	65.000	65.077	65.155	65.233	65.310	65.388	65.465	65.543	65.621	65.698	850
860	65.698	65.776	65.853	65.931	66.008	66.086	66.163	66.241	66.318	66.396	66.473	860
870	66.473	66.550	66.628	66.705	66.782	66.860	66.937	67.014	67.092	67.169	67.246	870
880	67.246	67.323	67.400	67.478	67.555	67.632	67.709	67.786	67.863	67.940	68.017	880
890	68.017	68.094	68.171	68.248	68.325	68.402	68.479	68.556	68.633	68.710	68.787	890
900	68.787	68.863	68.940	69.017	69.094	69.171	69.247	69.324	69.401	69.477	69.554	900
910	69.554	69.631	69.707	69.784	69.860	69.937	70.013	70.090	70.166	70.243	70.319	910
920	70.319	70.396	70.472	70.548	70.625	70.701	70.777	70.854	70.930	71.006	71.082	920
930	71.082	71.159	71.235	71.311	71.387	71.463	71.539	71.615	71.692	71.768	71.844	930
940	71.844	71.920	71.996	72.072	72.147	72.223	72.299	72.375	72.451	72.527	72.603	940
950	72.603	72.678	72.754	72.830	72.906	72.981	73.057	73.133	73.208	73.284	73.360	950
960	73.360	73.435	73.511	73.586	73.662	73.738	73.813	73.889	73.964	74.040	74.115	960
970	74.115	74.190	74.266	74.341	74.417	74.492	74.567	74.643	74.718	74.793	74.869	970
980	74.869	74.944	75.019	75.095	75.170	75.245	75.320	75.395	75.471	75.546	75.621	980
990	75.621	75.696	75.771	75.847	75.922	75.997	76.072	76.147	76.223	76.298	76.373	990
1000	76.373											1000

°C 0 1 2 3 4 5 6 7 8 9 10 °C

قياس الحرارة Temperature Measurement - شركة النفط السورية (مديرية حقول الحسكة - الرميلان)
إعداد وتنفيذ / المهندس / محمود عبد الفتاح أحمد أبو الفتوح / المدرب المصرى للأجهزة الدقيقة

2009/2010

Mob. 01148695492

E.Mail mahmodcontrol@yahoo.com

B°C**TABLE 3 Type B Thermocouple — thermoelectric voltage as a function of temperature (°C); reference junctions at 0 °C**

°C	0	1	2	3	4	5	6	7	8	9	10	°C
Thermoelectric Voltage in Millivolts												
0	0.000	0.000	0.000	-0.001	-0.001	-0.001	-0.001	-0.001	-0.002	-0.002	-0.002	0
10	-0.002	-0.002	-0.002	-0.002	-0.002	-0.002	-0.002	-0.002	-0.003	-0.003	-0.003	10
20	-0.003	-0.003	-0.003	-0.003	-0.003	-0.002	-0.002	-0.002	-0.002	-0.002	-0.002	20
30	-0.002	-0.002	-0.002	-0.002	-0.002	-0.001	-0.001	-0.001	-0.001	-0.001	0.000	30
40	0.000	0.000	0.000	0.000	0.000	0.001	0.001	0.001	0.002	0.002	0.002	40
50	0.002	0.003	0.003	0.003	0.004	0.004	0.004	0.005	0.005	0.006	0.006	50
60	0.006	0.007	0.007	0.008	0.008	0.009	0.009	0.010	0.010	0.011	0.011	60
70	0.011	0.012	0.012	0.013	0.014	0.014	0.015	0.015	0.016	0.017	0.017	70
80	0.017	0.018	0.019	0.020	0.020	0.021	0.022	0.022	0.023	0.024	0.025	80
90	0.025	0.026	0.026	0.027	0.028	0.029	0.030	0.031	0.031	0.032	0.033	90
100	0.033	0.034	0.035	0.036	0.037	0.038	0.039	0.040	0.041	0.042	0.043	100
110	0.043	0.044	0.045	0.046	0.047	0.048	0.049	0.050	0.051	0.052	0.053	110
120	0.053	0.055	0.056	0.057	0.058	0.059	0.060	0.062	0.063	0.064	0.065	120
130	0.065	0.066	0.068	0.069	0.070	0.072	0.073	0.074	0.075	0.077	0.078	130
140	0.078	0.079	0.081	0.082	0.084	0.085	0.086	0.088	0.089	0.091	0.092	140
150	0.092	0.094	0.095	0.096	0.098	0.099	0.101	0.102	0.104	0.106	0.107	150
160	0.107	0.109	0.110	0.112	0.113	0.115	0.117	0.118	0.120	0.122	0.123	160
170	0.123	0.125	0.127	0.128	0.130	0.132	0.134	0.135	0.137	0.139	0.141	170
180	0.141	0.142	0.144	0.146	0.148	0.150	0.151	0.153	0.155	0.157	0.159	180
190	0.159	0.161	0.163	0.165	0.166	0.168	0.170	0.172	0.174	0.176	0.178	190
200	0.178	0.180	0.182	0.184	0.186	0.188	0.190	0.192	0.195	0.197	0.199	200
210	0.199	0.201	0.203	0.205	0.207	0.209	0.212	0.214	0.216	0.218	0.220	210
220	0.220	0.222	0.225	0.227	0.229	0.231	0.234	0.236	0.238	0.241	0.243	220
230	0.243	0.245	0.248	0.250	0.252	0.255	0.257	0.259	0.262	0.264	0.267	230
240	0.267	0.269	0.271	0.274	0.276	0.279	0.281	0.284	0.286	0.289	0.291	240
250	0.291	0.294	0.296	0.299	0.301	0.304	0.307	0.309	0.312	0.314	0.317	250
260	0.317	0.320	0.322	0.325	0.328	0.330	0.333	0.336	0.338	0.341	0.344	260
270	0.344	0.347	0.349	0.352	0.355	0.358	0.360	0.363	0.366	0.369	0.372	270
280	0.372	0.375	0.377	0.380	0.383	0.386	0.389	0.392	0.395	0.398	0.401	280
290	0.401	0.404	0.407	0.410	0.413	0.416	0.419	0.422	0.425	0.428	0.431	290
300	0.431	0.434	0.437	0.440	0.443	0.446	0.449	0.452	0.455	0.458	0.462	300
310	0.462	0.465	0.468	0.471	0.474	0.478	0.481	0.484	0.487	0.490	0.494	310
320	0.494	0.497	0.500	0.503	0.507	0.510	0.513	0.517	0.520	0.523	0.527	320
330	0.527	0.530	0.533	0.537	0.540	0.544	0.547	0.550	0.554	0.557	0.561	330
340	0.561	0.564	0.568	0.571	0.575	0.578	0.582	0.585	0.589	0.592	0.596	340
350	0.596	0.599	0.603	0.607	0.610	0.614	0.617	0.621	0.625	0.628	0.632	350
360	0.632	0.636	0.639	0.643	0.647	0.650	0.654	0.658	0.662	0.665	0.669	360
370	0.669	0.673	0.677	0.680	0.684	0.688	0.692	0.696	0.700	0.703	0.707	370
380	0.707	0.711	0.715	0.719	0.723	0.727	0.731	0.735	0.738	0.742	0.746	380
390	0.746	0.750	0.754	0.758	0.762	0.766	0.770	0.774	0.778	0.782	0.787	390
400	0.787	0.791	0.795	0.799	0.803	0.807	0.811	0.815	0.819	0.824	0.828	400
410	0.828	0.832	0.836	0.840	0.844	0.849	0.853	0.857	0.861	0.866	0.870	410
420	0.870	0.874	0.878	0.883	0.887	0.891	0.896	0.900	0.904	0.909	0.913	420
430	0.913	0.917	0.922	0.926	0.930	0.935	0.939	0.944	0.948	0.953	0.957	430
440	0.957	0.961	0.966	0.970	0.975	0.979	0.984	0.988	0.993	0.997	1.002	440
450	1.002	1.007	1.011	1.016	1.020	1.025	1.030	1.034	1.039	1.043	1.048	450
460	1.048	1.053	1.057	1.062	1.067	1.071	1.076	1.081	1.086	1.090	1.095	460
470	1.095	1.100	1.105	1.109	1.114	1.119	1.124	1.129	1.133	1.138	1.143	470
480	1.143	1.148	1.153	1.158	1.163	1.167	1.172	1.177	1.182	1.187	1.192	480
490	1.192	1.197	1.202	1.207	1.212	1.217	1.222	1.227	1.232	1.237	1.242	490
°C	0	1	2	3	4	5	6	7	8	9	10	°C

TABLE 3 Type B Thermocouple — thermoelectric voltage as a function of temperature (°C); reference junctions at 0 °C

°C	0	1	2	3	4	5	6	7	8	9	10	°C
Thermoelectric Voltage in Millivolts												
500	1.242	1.247	1.252	1.257	1.262	1.267	1.272	1.277	1.282	1.288	1.293	500
510	1.293	1.298	1.303	1.308	1.313	1.318	1.324	1.329	1.334	1.339	1.344	510
520	1.344	1.350	1.355	1.360	1.365	1.371	1.376	1.381	1.387	1.392	1.397	520
530	1.397	1.402	1.408	1.413	1.418	1.424	1.429	1.435	1.440	1.445	1.451	530
540	1.451	1.456	1.462	1.467	1.472	1.478	1.483	1.489	1.494	1.500	1.505	540
550	1.505	1.511	1.516	1.522	1.527	1.533	1.539	1.544	1.550	1.555	1.561	550
560	1.561	1.566	1.572	1.578	1.583	1.589	1.595	1.600	1.606	1.612	1.617	560
570	1.617	1.623	1.629	1.634	1.640	1.646	1.652	1.657	1.663	1.669	1.675	570
580	1.675	1.680	1.686	1.692	1.698	1.704	1.709	1.715	1.721	1.727	1.733	580
590	1.733	1.739	1.745	1.750	1.756	1.762	1.768	1.774	1.780	1.786	1.792	590
600	1.792	1.798	1.804	1.810	1.816	1.822	1.828	1.834	1.840	1.846	1.852	600
610	1.852	1.858	1.864	1.870	1.876	1.882	1.888	1.894	1.901	1.907	1.913	610
620	1.913	1.919	1.925	1.931	1.937	1.944	1.950	1.956	1.962	1.968	1.975	620
630	1.975	1.981	1.987	1.993	1.999	2.006	2.012	2.018	2.025	2.031	2.037	630
640	2.037	2.043	2.050	2.056	2.062	2.069	2.075	2.082	2.088	2.094	2.101	640
650	2.101	2.107	2.113	2.120	2.126	2.133	2.139	2.146	2.152	2.158	2.165	650
660	2.165	2.171	2.178	2.184	2.191	2.197	2.204	2.210	2.217	2.224	2.230	660
670	2.230	2.237	2.243	2.250	2.256	2.263	2.270	2.276	2.283	2.289	2.296	670
680	2.296	2.303	2.309	2.316	2.323	2.329	2.336	2.343	2.350	2.356	2.363	680
690	2.363	2.370	2.376	2.383	2.390	2.397	2.403	2.410	2.417	2.424	2.431	690
700	2.431	2.437	2.444	2.451	2.458	2.465	2.472	2.479	2.485	2.492	2.499	700
710	2.499	2.506	2.513	2.520	2.527	2.534	2.541	2.548	2.555	2.562	2.569	710
720	2.569	2.576	2.583	2.590	2.597	2.604	2.611	2.618	2.625	2.632	2.639	720
730	2.639	2.646	2.653	2.660	2.667	2.674	2.681	2.688	2.696	2.703	2.710	730
740	2.710	2.717	2.724	2.731	2.738	2.746	2.753	2.760	2.767	2.775	2.782	740
750	2.782	2.789	2.796	2.803	2.811	2.818	2.825	2.833	2.840	2.847	2.854	750
760	2.854	2.862	2.869	2.876	2.884	2.891	2.898	2.906	2.913	2.921	2.928	760
770	2.928	2.935	2.943	2.950	2.958	2.965	2.973	2.980	2.987	2.995	3.002	770
780	3.002	3.010	3.017	3.025	3.032	3.040	3.047	3.055	3.062	3.070	3.078	780
790	3.078	3.085	3.093	3.100	3.108	3.116	3.123	3.131	3.138	3.146	3.154	790
800	3.154	3.161	3.169	3.177	3.184	3.192	3.200	3.207	3.215	3.223	3.230	800
810	3.230	3.238	3.246	3.254	3.261	3.269	3.277	3.285	3.292	3.300	3.308	810
820	3.308	3.316	3.324	3.331	3.339	3.347	3.355	3.363	3.371	3.379	3.386	820
830	3.386	3.394	3.402	3.410	3.418	3.426	3.434	3.442	3.450	3.458	3.466	830
840	3.466	3.474	3.482	3.490	3.498	3.506	3.514	3.522	3.530	3.538	3.546	840
850	3.546	3.554	3.562	3.570	3.578	3.586	3.594	3.602	3.610	3.618	3.626	850
860	3.626	3.634	3.643	3.651	3.659	3.667	3.675	3.683	3.692	3.700	3.708	860
870	3.708	3.716	3.724	3.732	3.741	3.749	3.757	3.765	3.774	3.782	3.790	870
880	3.790	3.798	3.807	3.815	3.823	3.832	3.840	3.848	3.857	3.865	3.873	880
890	3.873	3.882	3.890	3.898	3.907	3.915	3.923	3.932	3.940	3.949	3.957	890
900	3.957	3.965	3.974	3.982	3.991	3.999	4.008	4.016	4.024	4.033	4.041	900
910	4.041	4.050	4.058	4.067	4.075	4.084	4.093	4.101	4.110	4.118	4.127	910
920	4.127	4.135	4.144	4.152	4.161	4.170	4.178	4.187	4.195	4.204	4.213	920
930	4.213	4.221	4.230	4.239	4.247	4.256	4.265	4.273	4.282	4.291	4.299	930
940	4.299	4.308	4.317	4.326	4.334	4.343	4.352	4.360	4.369	4.378	4.387	940
950	4.387	4.396	4.404	4.413	4.422	4.431	4.440	4.448	4.457	4.466	4.475	950
960	4.475	4.484	4.493	4.501	4.510	4.519	4.528	4.537	4.546	4.555	4.564	960
970	4.564	4.573	4.582	4.591	4.599	4.608	4.617	4.626	4.635	4.644	4.653	970
980	4.653	4.662	4.671	4.680	4.689	4.698	4.707	4.716	4.725	4.734	4.743	980
990	4.743	4.753	4.762	4.771	4.780	4.789	4.798	4.807	4.816	4.825	4.834	990
°C	0	1	2	3	4	5	6	7	8	9	10	°C

B°C**TABLE 3 Type B Thermocouple — thermoelectric voltage as a function of temperature (°C); reference junctions at 0 °C**

°C	0	1	2	3	4	5	6	7	8	9	10	°C
Thermoelectric Voltage in Millivolts												
1000	4.834	4.843	4.853	4.862	4.871	4.880	4.889	4.898	4.908	4.917	4.926	1000
1010	4.926	4.935	4.944	4.954	4.963	4.972	4.981	4.990	5.000	5.009	5.018	1010
1020	5.018	5.027	5.037	5.046	5.055	5.065	5.074	5.083	5.092	5.102	5.111	1020
1030	5.111	5.120	5.130	5.139	5.148	5.158	5.167	5.176	5.186	5.195	5.205	1030
1040	5.205	5.214	5.223	5.233	5.242	5.252	5.261	5.270	5.280	5.289	5.299	1040
1050	5.299	5.308	5.318	5.327	5.337	5.346	5.356	5.365	5.375	5.384	5.394	1050
1060	5.394	5.403	5.413	5.422	5.432	5.441	5.451	5.460	5.470	5.480	5.489	1060
1070	5.489	5.499	5.508	5.518	5.528	5.537	5.547	5.556	5.566	5.576	5.585	1070
1080	5.585	5.595	5.605	5.614	5.624	5.634	5.643	5.653	5.663	5.672	5.682	1080
1090	5.682	5.692	5.702	5.711	5.721	5.731	5.740	5.750	5.760	5.770	5.780	1090
1100	5.780	5.789	5.799	5.809	5.819	5.828	5.838	5.848	5.858	5.868	5.878	1100
1110	5.878	5.887	5.897	5.907	5.917	5.927	5.937	5.947	5.956	5.966	5.976	1110
1120	5.976	5.986	5.996	6.006	6.016	6.026	6.036	6.046	6.055	6.065	6.075	1120
1130	6.075	6.085	6.095	6.105	6.115	6.125	6.135	6.145	6.155	6.165	6.175	1130
1140	6.175	6.185	6.195	6.205	6.215	6.225	6.235	6.245	6.256	6.266	6.276	1140
1150	6.276	6.286	6.296	6.306	6.316	6.326	6.336	6.346	6.356	6.367	6.377	1150
1160	6.377	6.387	6.397	6.407	6.417	6.427	6.438	6.448	6.458	6.468	6.478	1160
1170	6.478	6.488	6.499	6.509	6.519	6.529	6.539	6.550	6.560	6.570	6.580	1170
1180	6.580	6.591	6.601	6.611	6.621	6.632	6.642	6.652	6.663	6.673	6.683	1180
1190	6.683	6.693	6.704	6.714	6.724	6.735	6.745	6.755	6.766	6.776	6.786	1190
1200	6.786	6.797	6.807	6.818	6.828	6.838	6.849	6.859	6.869	6.880	6.890	1200
1210	6.890	6.901	6.911	6.922	6.932	6.942	6.953	6.963	6.974	6.984	6.995	1210
1220	6.995	7.005	7.016	7.026	7.037	7.047	7.058	7.068	7.079	7.089	7.100	1220
1230	7.100	7.110	7.121	7.131	7.142	7.152	7.163	7.173	7.184	7.194	7.205	1230
1240	7.205	7.216	7.226	7.237	7.247	7.258	7.269	7.279	7.290	7.300	7.311	1240
1250	7.311	7.322	7.332	7.343	7.353	7.364	7.375	7.385	7.396	7.407	7.417	1250
1260	7.417	7.428	7.439	7.449	7.460	7.471	7.482	7.492	7.503	7.514	7.524	1260
1270	7.524	7.535	7.546	7.557	7.567	7.578	7.589	7.600	7.610	7.621	7.632	1270
1280	7.632	7.643	7.653	7.664	7.675	7.686	7.697	7.707	7.718	7.729	7.740	1280
1290	7.740	7.751	7.761	7.772	7.783	7.794	7.805	7.816	7.827	7.837	7.848	1290
1300	7.848	7.859	7.870	7.881	7.892	7.903	7.914	7.924	7.935	7.946	7.957	1300
1310	7.957	7.968	7.979	7.990	8.001	8.012	8.023	8.034	8.045	8.056	8.066	1310
1320	8.066	8.077	8.088	8.099	8.110	8.121	8.132	8.143	8.154	8.165	8.176	1320
1330	8.176	8.187	8.198	8.209	8.220	8.231	8.242	8.253	8.264	8.275	8.286	1330
1340	8.286	8.298	8.309	8.320	8.331	8.342	8.353	8.364	8.375	8.386	8.397	1340
1350	8.397	8.408	8.419	8.430	8.441	8.453	8.464	8.475	8.486	8.497	8.508	1350
1360	8.508	8.519	8.530	8.542	8.553	8.564	8.575	8.586	8.597	8.608	8.620	1360
1370	8.620	8.631	8.642	8.653	8.664	8.675	8.687	8.698	8.709	8.720	8.731	1370
1380	8.731	8.743	8.754	8.765	8.776	8.787	8.799	8.810	8.821	8.832	8.844	1380
1390	8.844	8.855	8.866	8.877	8.889	8.900	8.911	8.922	8.934	8.945	8.956	1390
1400	8.956	8.967	8.979	8.990	9.001	9.013	9.024	9.035	9.047	9.058	9.069	1400
1410	9.069	9.080	9.092	9.103	9.114	9.126	9.137	9.148	9.160	9.171	9.182	1410
1420	9.182	9.194	9.205	9.216	9.228	9.239	9.251	9.262	9.273	9.285	9.296	1420
1430	9.296	9.307	9.319	9.330	9.342	9.353	9.364	9.376	9.387	9.398	9.410	1430
1440	9.410	9.421	9.433	9.444	9.456	9.467	9.478	9.490	9.501	9.513	9.524	1440
1450	9.524	9.536	9.547	9.558	9.570	9.581	9.593	9.604	9.616	9.627	9.639	1450
1460	9.639	9.650	9.662	9.673	9.684	9.696	9.707	9.719	9.730	9.742	9.753	1460
1470	9.753	9.765	9.776	9.788	9.799	9.811	9.822	9.834	9.845	9.857	9.868	1470
1480	9.868	9.880	9.891	9.903	9.914	9.926	9.937	9.949	9.961	9.972	9.984	1480
1490	9.984	9.995	10.007	10.018	10.030	10.041	10.053	10.064	10.076	10.088	10.099	1490
°C	0	1	2	3	4	5	6	7	8	9	10	°C

TABLE 3 Type B Thermocouple — thermoelectric voltage as a function of temperature (°C); reference junctions at 0 °C

°C	0	1	2	3	4	5	6	7	8	9	10	°C
Thermoelectric Voltage in Millivolts												
1500	10.099	10.111	10.122	10.134	10.145	10.157	10.168	10.180	10.192	10.203	10.215	1500
1510	10.215	10.226	10.238	10.249	10.261	10.273	10.284	10.296	10.307	10.319	10.331	1510
1520	10.331	10.342	10.354	10.365	10.377	10.389	10.400	10.412	10.423	10.435	10.447	1520
1530	10.447	10.458	10.470	10.482	10.493	10.505	10.516	10.528	10.540	10.551	10.563	1530
1540	10.563	10.575	10.586	10.598	10.609	10.621	10.633	10.644	10.656	10.668	10.679	1540
1550	10.679	10.691	10.703	10.714	10.726	10.738	10.749	10.761	10.773	10.784	10.796	1550
1560	10.796	10.808	10.819	10.831	10.843	10.854	10.866	10.877	10.889	10.901	10.913	1560
1570	10.913	10.924	10.936	10.948	10.959	10.971	10.983	10.994	11.006	11.018	11.029	1570
1580	11.029	11.041	11.053	11.064	11.076	11.088	11.099	11.111	11.123	11.134	11.146	1580
1590	11.146	11.158	11.169	11.181	11.193	11.205	11.216	11.228	11.240	11.251	11.263	1590
1600	11.263	11.275	11.286	11.298	11.310	11.321	11.333	11.345	11.357	11.368	11.380	1600
1610	11.380	11.392	11.403	11.415	11.427	11.438	11.450	11.462	11.474	11.485	11.497	1610
1620	11.497	11.509	11.520	11.532	11.544	11.555	11.567	11.579	11.591	11.602	11.614	1620
1630	11.614	11.626	11.637	11.649	11.661	11.673	11.684	11.696	11.708	11.719	11.731	1630
1640	11.731	11.743	11.754	11.766	11.778	11.790	11.801	11.813	11.825	11.836	11.848	1640
1650	11.848	11.860	11.871	11.883	11.895	11.907	11.918	11.930	11.942	11.953	11.965	1650
1660	11.965	11.977	11.988	12.000	12.012	12.024	12.035	12.047	12.059	12.070	12.082	1660
1670	12.082	12.094	12.105	12.117	12.129	12.141	12.152	12.164	12.176	12.187	12.199	1670
1680	12.199	12.211	12.222	12.234	12.246	12.257	12.269	12.281	12.292	12.304	12.316	1680
1690	12.316	12.327	12.339	12.351	12.363	12.374	12.386	12.398	12.409	12.421	12.433	1690
1700	12.433	12.444	12.456	12.468	12.479	12.491	12.503	12.514	12.526	12.538	12.549	1700
1710	12.549	12.561	12.572	12.584	12.596	12.607	12.619	12.631	12.642	12.654	12.666	1710
1720	12.666	12.677	12.689	12.701	12.712	12.724	12.736	12.747	12.759	12.770	12.782	1720
1730	12.782	12.794	12.805	12.817	12.829	12.840	12.852	12.863	12.875	12.887	12.898	1730
1740	12.898	12.910	12.921	12.933	12.945	12.956	12.968	12.980	12.991	13.003	13.014	1740
1750	13.014	13.026	13.037	13.049	13.061	13.072	13.084	13.095	13.107	13.119	13.130	1750
1760	13.130	13.142	13.153	13.165	13.176	13.188	13.200	13.211	13.223	13.234	13.246	1760
1770	13.246	13.257	13.269	13.280	13.292	13.304	13.315	13.327	13.338	13.350	13.361	1770
1780	13.361	13.373	13.384	13.396	13.407	13.419	13.430	13.442	13.453	13.465	13.476	1780
1790	13.476	13.488	13.499	13.511	13.522	13.534	13.545	13.557	13.568	13.580	13.591	1790
1800	13.591	13.603	13.614	13.626	13.637	13.649	13.660	13.672	13.683	13.694	13.706	1800
1810	13.706	13.717	13.729	13.740	13.752	13.763	13.775	13.786	13.797	13.809	13.820	1810
1820	13.820											1820

°C 0 1 2 3 4 5 6 7 8 9 10 °C



TABLE 21 Type C Thermocouple — thermoelectric voltage as a function of temperature (°C); reference junctions at 0 °C

°C	0	1	2	3	4	5	6	7	8	9	10	°C
Thermoelectric Voltage in Millivolts												
0	0.000	0.013	0.027	0.040	0.054	0.067	0.081	0.094	0.108	0.121	0.135	0
10	0.135	0.149	0.162	0.176	0.190	0.204	0.217	0.231	0.245	0.259	0.273	10
20	0.273	0.286	0.300	0.314	0.328	0.342	0.356	0.370	0.384	0.398	0.412	20
30	0.412	0.426	0.441	0.455	0.469	0.483	0.497	0.512	0.526	0.540	0.554	30
40	0.554	0.569	0.583	0.598	0.612	0.626	0.641	0.655	0.670	0.684	0.699	40
50	0.699	0.713	0.728	0.742	0.757	0.772	0.786	0.801	0.816	0.830	0.845	50
60	0.845	0.860	0.875	0.889	0.904	0.919	0.934	0.949	0.964	0.979	0.994	60
70	0.994	1.009	1.024	1.039	1.054	1.069	1.084	1.099	1.114	1.129	1.144	70
80	1.144	1.159	1.175	1.190	1.205	1.220	1.235	1.251	1.266	1.281	1.297	80
90	1.297	1.312	1.327	1.343	1.358	1.374	1.389	1.405	1.420	1.436	1.451	90
100	1.451	1.467	1.482	1.498	1.513	1.529	1.545	1.560	1.576	1.592	1.607	100
110	1.607	1.623	1.639	1.655	1.670	1.686	1.702	1.718	1.734	1.750	1.766	110
120	1.766	1.781	1.797	1.813	1.829	1.845	1.861	1.877	1.893	1.909	1.925	120
130	1.925	1.942	1.958	1.974	1.990	2.006	2.022	2.038	2.055	2.071	2.087	130
140	2.087	2.103	2.120	2.136	2.152	2.168	2.185	2.201	2.217	2.234	2.250	140
150	2.250	2.267	2.283	2.300	2.316	2.332	2.349	2.365	2.382	2.398	2.415	150
160	2.415	2.432	2.448	2.465	2.481	2.498	2.515	2.531	2.548	2.565	2.581	160
170	2.581	2.598	2.615	2.632	2.648	2.665	2.682	2.699	2.716	2.732	2.749	170
180	2.749	2.766	2.783	2.800	2.817	2.834	2.851	2.868	2.885	2.902	2.919	180
190	2.919	2.936	2.953	2.970	2.987	3.004	3.021	3.038	3.055	3.072	3.089	190
200	3.089	3.106	3.124	3.141	3.158	3.175	3.192	3.210	3.227	3.244	3.261	200
210	3.261	3.279	3.296	3.313	3.331	3.348	3.365	3.383	3.400	3.417	3.435	210
220	3.435	3.452	3.470	3.487	3.505	3.522	3.539	3.557	3.574	3.592	3.609	220
230	3.609	3.627	3.645	3.662	3.680	3.697	3.715	3.732	3.750	3.768	3.785	230
240	3.785	3.803	3.821	3.838	3.856	3.874	3.891	3.909	3.927	3.945	3.962	240
250	3.962	3.980	3.998	4.016	4.034	4.051	4.069	4.087	4.105	4.123	4.141	250
260	4.141	4.158	4.176	4.194	4.212	4.230	4.248	4.266	4.284	4.302	4.320	260
270	4.320	4.338	4.356	4.374	4.392	4.410	4.428	4.446	4.464	4.482	4.500	270
280	4.500	4.518	4.536	4.554	4.573	4.591	4.609	4.627	4.645	4.663	4.682	280
290	4.682	4.700	4.718	4.736	4.754	4.773	4.791	4.809	4.827	4.846	4.864	290
300	4.864	4.882	4.900	4.919	4.937	4.955	4.974	4.992	5.010	5.029	5.047	300
310	5.047	5.065	5.084	5.102	5.121	5.139	5.157	5.176	5.194	5.213	5.231	310
320	5.231	5.250	5.268	5.287	5.305	5.323	5.342	5.361	5.379	5.398	5.416	320
330	5.416	5.435	5.453	5.472	5.490	5.509	5.527	5.546	5.565	5.583	5.602	330
340	5.602	5.620	5.639	5.658	5.676	5.695	5.714	5.732	5.751	5.770	5.788	340
350	5.788	5.807	5.826	5.844	5.863	5.882	5.901	5.919	5.938	5.957	5.976	350
360	5.976	5.994	6.013	6.032	6.051	6.070	6.088	6.107	6.126	6.145	6.164	360
370	6.164	6.182	6.201	6.220	6.239	6.258	6.277	6.296	6.314	6.333	6.352	370
380	6.352	6.371	6.390	6.409	6.428	6.447	6.466	6.485	6.504	6.523	6.541	380
390	6.541	6.560	6.579	6.598	6.617	6.636	6.655	6.674	6.693	6.712	6.731	390
400	6.731	6.750	6.769	6.788	6.807	6.826	6.845	6.865	6.884	6.903	6.922	400
410	6.922	6.941	6.960	6.979	6.998	7.017	7.036	7.055	7.074	7.094	7.113	410
420	7.113	7.132	7.151	7.170	7.189	7.208	7.227	7.247	7.266	7.285	7.304	420
430	7.304	7.323	7.342	7.362	7.381	7.400	7.419	7.438	7.458	7.477	7.496	430
440	7.496	7.515	7.534	7.554	7.573	7.592	7.611	7.631	7.650	7.669	7.688	440
450	7.688	7.708	7.727	7.746	7.765	7.785	7.804	7.823	7.842	7.862	7.881	450
460	7.881	7.900	7.920	7.939	7.958	7.978	7.997	8.016	8.036	8.055	8.074	460
470	8.074	8.094	8.113	8.132	8.152	8.171	8.190	8.210	8.229	8.248	8.268	470
480	8.268	8.287	8.306	8.326	8.345	8.364	8.384	8.403	8.423	8.442	8.461	480
490	8.461	8.481	8.500	8.520	8.539	8.558	8.578	8.597	8.617	8.636	8.655	490

TABLE 21 Type C Thermocouple — thermoelectric voltage as a function of temperature (°C); reference junctions at 0 °C

°C	0	1	2	3	4	5	6	7	8	9	10	°C
Thermoelectric Voltage in Millivolts												
500	8.655	8.675	8.694	8.714	8.733	8.753	8.772	8.791	8.811	8.830	8.850	500
510	8.850	8.869	8.889	8.908	8.928	8.947	8.966	8.986	9.005	9.025	9.044	510
520	9.044	9.064	9.083	9.103	9.122	9.142	9.161	9.181	9.200	9.220	9.239	520
530	9.239	9.259	9.278	9.298	9.317	9.337	9.356	9.376	9.395	9.415	9.434	530
540	9.434	9.454	9.473	9.493	9.512	9.532	9.551	9.571	9.590	9.610	9.629	540
550	9.629	9.649	9.668	9.688	9.707	9.727	9.746	9.766	9.785	9.805	9.824	550
560	9.824	9.844	9.863	9.883	9.902	9.922	9.942	9.961	9.981	10.000	10.020	560
570	10.020	10.039	10.059	10.078	10.098	10.117	10.137	10.156	10.176	10.196	10.215	570
580	10.215	10.235	10.254	10.274	10.293	10.313	10.332	10.352	10.371	10.391	10.411	580
590	10.411	10.430	10.450	10.469	10.489	10.508	10.528	10.547	10.567	10.587	10.606	590
600	10.606	10.626	10.645	10.665	10.684	10.704	10.723	10.743	10.763	10.782	10.802	600
610	10.802	10.821	10.841	10.860	10.880	10.899	10.919	10.939	10.958	10.978	10.997	610
620	10.997	11.017	11.036	11.056	11.075	11.095	11.114	11.134	11.154	11.173	11.193	620
630	11.193	11.212	11.232	11.251	11.271	11.290	11.310	11.330	11.349	11.369	11.388	630
640	11.388	11.408	11.427	11.447	11.466	11.486	11.505	11.525	11.544	11.564	11.584	640
650	11.584	11.603	11.623	11.642	11.662	11.681	11.701	11.720	11.740	11.759	11.779	650
660	11.779	11.798	11.818	11.837	11.857	11.876	11.896	11.915	11.935	11.955	11.974	660
670	11.974	11.994	12.013	12.033	12.052	12.072	12.091	12.111	12.130	12.150	12.169	670
680	12.169	12.189	12.208	12.228	12.247	12.267	12.286	12.306	12.325	12.345	12.364	680
690	12.364	12.384	12.403	12.422	12.442	12.461	12.481	12.500	12.520	12.539	12.559	690
700	12.559	12.578	12.598	12.617	12.637	12.656	12.676	12.695	12.715	12.734	12.753	700
710	12.753	12.773	12.792	12.812	12.831	12.851	12.870	12.890	12.909	12.928	12.948	710
720	12.948	12.967	12.987	13.006	13.026	13.045	13.064	13.084	13.103	13.123	13.142	720
730	13.142	13.161	13.181	13.200	13.220	13.239	13.258	13.278	13.297	13.317	13.336	730
740	13.336	13.355	13.375	13.394	13.413	13.433	13.452	13.472	13.491	13.510	13.530	740
750	13.530	13.549	13.568	13.588	13.607	13.626	13.646	13.665	13.685	13.704	13.723	750
760	13.723	13.743	13.762	13.781	13.800	13.820	13.839	13.858	13.878	13.897	13.916	760
770	13.916	13.936	13.955	13.974	13.994	14.013	14.032	14.051	14.071	14.090	14.109	770
780	14.109	14.129	14.148	14.167	14.186	14.206	14.225	14.244	14.263	14.283	14.302	780
790	14.302	14.321	14.340	14.360	14.379	14.398	14.417	14.437	14.456	14.475	14.494	790
800	14.494	14.513	14.533	14.552	14.571	14.590	14.609	14.629	14.648	14.667	14.686	800
810	14.686	14.705	14.725	14.744	14.763	14.782	14.801	14.820	14.840	14.859	14.878	810
820	14.878	14.897	14.916	14.935	14.954	14.974	14.993	15.012	15.031	15.050	15.069	820
830	15.069	15.088	15.107	15.126	15.146	15.165	15.184	15.203	15.222	15.241	15.260	830
840	15.260	15.279	15.298	15.317	15.336	15.355	15.374	15.393	15.413	15.432	15.451	840
850	15.451	15.470	15.489	15.508	15.527	15.546	15.565	15.584	15.603	15.622	15.641	850
860	15.641	15.660	15.679	15.698	15.717	15.736	15.755	15.774	15.793	15.812	15.831	860
870	15.831	15.849	15.868	15.887	15.906	15.925	15.944	15.963	15.982	16.001	16.020	870
880	16.020	16.039	16.058	16.077	16.096	16.114	16.133	16.152	16.171	16.190	16.209	880
890	16.209	16.228	16.247	16.265	16.284	16.303	16.322	16.341	16.360	16.379	16.397	890
900	16.397	16.416	16.435	16.454	16.473	16.491	16.510	16.529	16.548	16.567	16.585	900
910	16.585	16.604	16.623	16.642	16.661	16.679	16.698	16.717	16.736	16.754	16.773	910
920	16.773	16.792	16.811	16.829	16.848	16.867	16.886	16.904	16.923	16.942	16.960	920
930	16.960	16.979	16.998	17.016	17.035	17.054	17.072	17.091	17.110	17.128	17.147	930
940	17.147	17.166	17.184	17.203	17.222	17.240	17.259	17.278	17.296	17.315	17.333	940
950	17.333	17.352	17.371	17.389	17.408	17.426	17.445	17.463	17.482	17.501	17.519	950
960	17.519	17.538	17.556	17.575	17.593	17.612	17.630	17.649	17.667	17.686	17.704	960
970	17.704	17.723	17.741	17.760	17.778	17.797	17.815	17.834	17.852	17.871	17.889	970
980	17.889	17.908	17.926	17.945	17.963	17.981	18.000	18.018	18.037	18.055	18.074	980
990	18.074	18.092	18.110	18.129	18.147	18.166	18.184	18.202	18.221	18.239	18.257	990
°C	0	1	2	3	4	5	6	7	8	9	10	°C



TABLE 21 Type C Thermocouple — thermoelectric voltage as a function of temperature (°C); reference junctions at 0 °C

°C	0	1	2	3	4	5	6	7	8	9	10	°C
Thermoelectric Voltage in Millivolts												
1000	18.257	18.276	18.294	18.312	18.331	18.349	18.367	18.386	18.404	18.422	18.441	1000
1010	18.441	18.459	18.477	18.496	18.514	18.532	18.550	18.569	18.587	18.605	18.623	1010
1020	18.623	18.642	18.660	18.678	18.696	18.715	18.733	18.751	18.769	18.788	18.806	1020
1030	18.806	18.824	18.842	18.860	18.878	18.897	18.915	18.933	18.951	18.969	18.987	1030
1040	18.987	19.006	19.024	19.042	19.060	19.078	19.096	19.114	19.132	19.151	19.169	1040
1050	19.169	19.187	19.205	19.223	19.241	19.259	19.277	19.295	19.313	19.331	19.349	1050
1060	19.349	19.367	19.385	19.403	19.421	19.439	19.457	19.475	19.493	19.511	19.529	1060
1070	19.529	19.547	19.565	19.583	19.601	19.619	19.637	19.655	19.673	19.691	19.709	1070
1080	19.709	19.727	19.745	19.763	19.781	19.799	19.816	19.834	19.852	19.870	19.888	1080
1090	19.888	19.906	19.924	19.942	19.959	19.977	19.995	20.013	20.031	20.049	20.066	1090
1100	20.066	20.084	20.102	20.120	20.138	20.155	20.173	20.191	20.209	20.227	20.244	1100
1110	20.244	20.262	20.280	20.298	20.315	20.333	20.351	20.369	20.386	20.404	20.422	1110
1120	20.422	20.439	20.457	20.475	20.492	20.510	20.528	20.546	20.563	20.581	20.598	1120
1130	20.598	20.616	20.634	20.651	20.669	20.687	20.704	20.722	20.739	20.757	20.775	1130
1140	20.775	20.792	20.810	20.827	20.845	20.863	20.880	20.898	20.915	20.933	20.950	1140
1150	20.950	20.968	20.985	21.003	21.020	21.038	21.055	21.073	21.090	21.108	21.125	1150
1160	21.125	21.143	21.160	21.178	21.195	21.213	21.230	21.248	21.265	21.282	21.300	1160
1170	21.300	21.317	21.335	21.352	21.369	21.387	21.404	21.422	21.439	21.456	21.474	1170
1180	21.474	21.491	21.508	21.526	21.543	21.560	21.578	21.595	21.612	21.630	21.647	1180
1190	21.647	21.664	21.682	21.699	21.716	21.733	21.751	21.768	21.785	21.802	21.820	1190
1200	21.820	21.837	21.854	21.871	21.889	21.906	21.923	21.940	21.957	21.975	21.992	1200
1210	21.992	22.009	22.026	22.043	22.061	22.078	22.095	22.112	22.129	22.146	22.163	1210
1220	22.163	22.180	22.198	22.215	22.232	22.249	22.266	22.283	22.300	22.317	22.334	1220
1230	22.334	22.351	22.368	22.385	22.403	22.420	22.437	22.454	22.471	22.488	22.505	1230
1240	22.505	22.522	22.539	22.556	22.573	22.590	22.607	22.624	22.641	22.657	22.674	1240
1250	22.674	22.691	22.708	22.725	22.742	22.759	22.776	22.793	22.810	22.827	22.844	1250
1260	22.844	22.860	22.877	22.894	22.911	22.928	22.945	22.962	22.978	22.995	23.012	1260
1270	23.012	23.029	23.046	23.063	23.079	23.096	23.113	23.130	23.147	23.163	23.180	1270
1280	23.180	23.197	23.214	23.230	23.247	23.264	23.281	23.297	23.314	23.331	23.347	1280
1290	23.347	23.364	23.381	23.398	23.414	23.431	23.448	23.464	23.481	23.498	23.514	1290
1300	23.514	23.531	23.548	23.564	23.581	23.597	23.614	23.631	23.647	23.664	23.680	1300
1310	23.680	23.697	23.714	23.730	23.747	23.763	23.780	23.796	23.813	23.829	23.846	1310
1320	23.846	23.862	23.879	23.895	23.912	23.928	23.945	23.961	23.978	23.994	24.011	1320
1330	24.011	24.027	24.044	24.060	24.077	24.093	24.110	24.126	24.142	24.159	24.175	1330
1340	24.175	24.192	24.208	24.224	24.241	24.257	24.274	24.290	24.306	24.323	24.339	1340
1350	24.339	24.355	24.372	24.388	24.404	24.421	24.437	24.453	24.470	24.486	24.502	1350
1360	24.502	24.518	24.535	24.551	24.567	24.583	24.600	24.616	24.632	24.648	24.665	1360
1370	24.665	24.681	24.697	24.713	24.730	24.746	24.762	24.778	24.794	24.810	24.827	1370
1380	24.827	24.843	24.859	24.875	24.891	24.907	24.923	24.940	24.956	24.972	24.988	1380
1390	24.988	25.004	25.020	25.036	25.052	25.068	25.084	25.100	25.117	25.133	25.149	1390
1400	25.149	25.165	25.181	25.197	25.213	25.229	25.245	25.261	25.277	25.293	25.309	1400
1410	25.309	25.325	25.341	25.357	25.373	25.389	25.405	25.420	25.436	25.452	25.468	1410
1420	25.468	25.484	25.500	25.516	25.532	25.548	25.564	25.580	25.595	25.611	25.627	1420
1430	25.627	25.643	25.659	25.675	25.691	25.706	25.722	25.738	25.754	25.770	25.785	1430
1440	25.785	25.801	25.817	25.833	25.849	25.864	25.880	25.896	25.912	25.927	25.943	1440
1450	25.943	25.959	25.975	25.990	26.006	26.022	26.038	26.053	26.069	26.085	26.100	1450
1460	26.100	26.116	26.132	26.147	26.163	26.179	26.194	26.210	26.226	26.241	26.257	1460
1470	26.257	26.272	26.288	26.304	26.319	26.335	26.350	26.366	26.382	26.397	26.413	1470
1480	26.413	26.428	26.444	26.459	26.475	26.490	26.506	26.521	26.537	26.552	26.568	1480
1490	26.568	26.583	26.599	26.614	26.630	26.645	26.661	26.676	26.692	26.707	26.723	1490

TABLE 21 Type C Thermocouple — thermoelectric voltage as a function of temperature (°C); reference junctions at 0 °C

°C	0	1	2	3	4	5	6	7	8	9	10	°C
Thermoelectric Voltage in Millivolts												
1500	26.723	26.738	26.753	26.769	26.784	26.800	26.815	26.830	26.846	26.861	26.877	1500
1510	26.877	26.892	26.907	26.923	26.938	26.953	26.969	26.984	26.999	27.015	27.030	1510
1520	27.030	27.045	27.061	27.076	27.091	27.107	27.122	27.137	27.152	27.168	27.183	1520
1530	27.183	27.198	27.213	27.229	27.244	27.259	27.274	27.290	27.305	27.320	27.335	1530
1540	27.335	27.350	27.366	27.381	27.396	27.411	27.426	27.441	27.457	27.472	27.487	1540
1550	27.487	27.502	27.517	27.532	27.547	27.562	27.578	27.593	27.608	27.623	27.638	1550
1560	27.638	27.653	27.668	27.683	27.698	27.713	27.728	27.743	27.758	27.773	27.788	1560
1570	27.788	27.803	27.818	27.833	27.848	27.863	27.878	27.893	27.908	27.923	27.938	1570
1580	27.938	27.953	27.968	27.983	27.998	28.013	28.028	28.043	28.058	28.072	28.087	1580
1590	28.087	28.102	28.117	28.132	28.147	28.162	28.177	28.191	28.206	28.221	28.236	1590
1600	28.236	28.251	28.266	28.280	28.295	28.310	28.325	28.340	28.354	28.369	28.384	1600
1610	28.384	28.399	28.413	28.428	28.443	28.458	28.472	28.487	28.502	28.517	28.531	1610
1620	28.531	28.546	28.561	28.575	28.590	28.605	28.619	28.634	28.649	28.663	28.678	1620
1630	28.678	28.693	28.707	28.722	28.737	28.751	28.766	28.780	28.795	28.810	28.824	1630
1640	28.824	28.839	28.853	28.868	28.883	28.897	28.912	28.926	28.941	28.955	28.970	1640
1650	28.970	28.984	28.999	29.013	29.028	29.042	29.057	29.071	29.086	29.100	29.115	1650
1660	29.115	29.129	29.144	29.158	29.173	29.187	29.201	29.216	29.230	29.245	29.259	1660
1670	29.259	29.274	29.288	29.302	29.317	29.331	29.345	29.360	29.374	29.388	29.403	1670
1680	29.403	29.417	29.431	29.446	29.460	29.474	29.489	29.503	29.517	29.532	29.546	1680
1690	29.546	29.560	29.574	29.589	29.603	29.617	29.631	29.646	29.660	29.674	29.688	1690
1700	29.688	29.703	29.717	29.731	29.745	29.759	29.774	29.788	29.802	29.816	29.830	1700
1710	29.830	29.844	29.859	29.873	29.887	29.901	29.915	29.929	29.943	29.957	29.971	1710
1720	29.971	29.986	30.000	30.014	30.028	30.042	30.056	30.070	30.084	30.098	30.112	1720
1730	30.112	30.126	30.140	30.154	30.168	30.182	30.196	30.210	30.224	30.238	30.252	1730
1740	30.252	30.266	30.280	30.294	30.308	30.322	30.336	30.350	30.364	30.378	30.391	1740
1750	30.391	30.405	30.419	30.433	30.447	30.461	30.475	30.489	30.502	30.516	30.530	1750
1760	30.530	30.544	30.558	30.572	30.585	30.599	30.613	30.627	30.641	30.654	30.668	1760
1770	30.668	30.682	30.696	30.710	30.723	30.737	30.751	30.765	30.778	30.792	30.806	1770
1780	30.806	30.819	30.833	30.847	30.861	30.874	30.888	30.902	30.915	30.929	30.943	1780
1790	30.943	30.956	30.970	30.983	30.997	31.011	31.024	31.038	31.052	31.065	31.079	1790
1800	31.079	31.092	31.106	31.119	31.133	31.147	31.160	31.174	31.187	31.201	31.214	1800
1810	31.214	31.228	31.241	31.255	31.268	31.282	31.295	31.309	31.322	31.336	31.349	1810
1820	31.349	31.363	31.376	31.389	31.403	31.416	31.430	31.443	31.457	31.470	31.483	1820
1830	31.483	31.497	31.510	31.524	31.537	31.550	31.564	31.577	31.590	31.604	31.617	1830
1840	31.617	31.630	31.644	31.657	31.670	31.683	31.697	31.710	31.723	31.737	31.750	1840
1850	31.750	31.763	31.776	31.790	31.803	31.816	31.829	31.842	31.856	31.869	31.882	1850
1860	31.882	31.895	31.908	31.922	31.935	31.948	31.961	31.974	31.987	32.001	32.014	1860
1870	32.014	32.027	32.040	32.053	32.066	32.079	32.092	32.105	32.118	32.132	32.145	1870
1880	32.145	32.158	32.171	32.184	32.197	32.210	32.223	32.236	32.249	32.262	32.275	1880
1890	32.275	32.288	32.301	32.314	32.327	32.340	32.353	32.366	32.378	32.391	32.404	1890
1900	32.404	32.417	32.430	32.443	32.456	32.469	32.482	32.495	32.507	32.520	32.533	1900
1910	32.533	32.546	32.559	32.572	32.584	32.597	32.610	32.623	32.636	32.649	32.661	1910
1920	32.661	32.674	32.687	32.700	32.712	32.725	32.738	32.751	32.763	32.776	32.789	1920
1930	32.789	32.801	32.814	32.827	32.840	32.852	32.865	32.878	32.890	32.903	32.915	1930
1940	32.915	32.928	32.941	32.953	32.966	32.979	32.991	33.004	33.016	33.029	33.041	1940
1950	33.041	33.054	33.067	33.079	33.092	33.104	33.117	33.129	33.142	33.154	33.167	1950
1960	33.167	33.179	33.192	33.204	33.217	33.229	33.242	33.254	33.266	33.279	33.291	1960
1970	33.291	33.304	33.316	33.329	33.341	33.353	33.366	33.378	33.390	33.403	33.415	1970
1980	33.415	33.427	33.440	33.452	33.464	33.477	33.489	33.501	33.514	33.526	33.538	1980
1990	33.538	33.550	33.563	33.575	33.587	33.599	33.612	33.624	33.636	33.648	33.660	1990
°C	0	1	2	3	4	5	6	7	8	9	10	°C

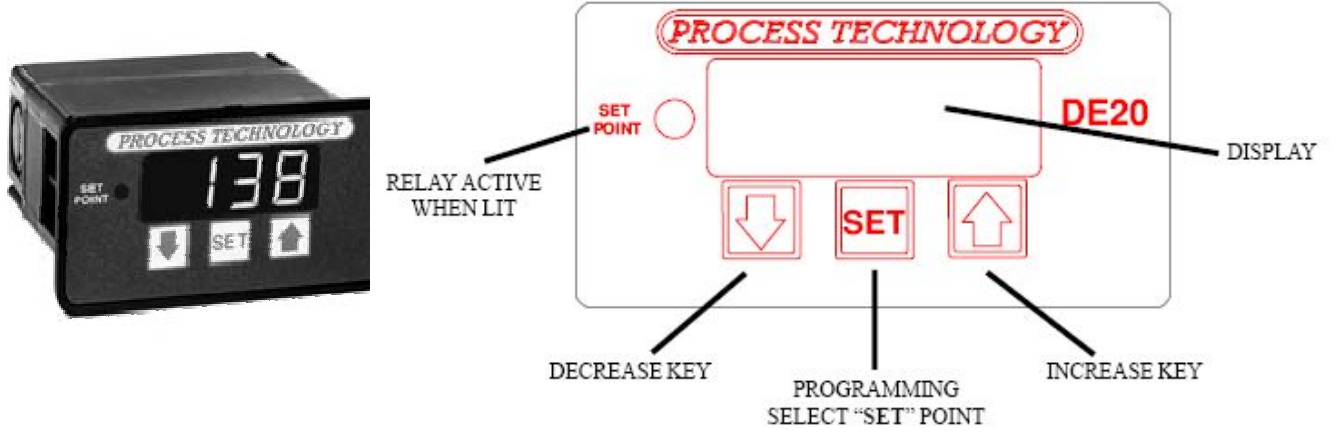

TABLE 21 Type C Thermocouple — thermoelectric voltage as a function of temperature (°C); reference junctions at 0 °C

°C	0	1	2	3	4	5	6	7	8	9	10	°C
Thermoelectric Voltage in Millivolts												
2000	33.660	33.673	33.685	33.697	33.709	33.721	33.733	33.746	33.758	33.770	33.782	2000
2010	33.782	33.794	33.806	33.818	33.830	33.842	33.855	33.867	33.879	33.891	33.903	2010
2020	33.903	33.915	33.927	33.939	33.951	33.963	33.975	33.987	33.999	34.011	34.023	2020
2030	34.023	34.035	34.047	34.059	34.071	34.082	34.094	34.106	34.118	34.130	34.142	2030
2040	34.142	34.154	34.166	34.178	34.189	34.201	34.213	34.225	34.237	34.249	34.260	2040
2050	34.260	34.272	34.284	34.296	34.307	34.319	34.331	34.343	34.354	34.366	34.378	2050
2060	34.378	34.390	34.401	34.413	34.425	34.436	34.448	34.460	34.471	34.483	34.495	2060
2070	34.495	34.506	34.518	34.530	34.541	34.553	34.564	34.576	34.587	34.599	34.611	2070
2080	34.611	34.622	34.634	34.645	34.657	34.668	34.680	34.691	34.703	34.714	34.726	2080
2090	34.726	34.737	34.749	34.760	34.771	34.783	34.794	34.806	34.817	34.829	34.840	2090
2100	34.840	34.851	34.863	34.874	34.885	34.897	34.908	34.919	34.931	34.942	34.953	2100
2110	34.953	34.965	34.976	34.987	34.998	35.010	35.021	35.032	35.043	35.055	35.066	2110
2120	35.066	35.077	35.088	35.099	35.110	35.122	35.133	35.144	35.155	35.166	35.177	2120
2130	35.177	35.188	35.199	35.211	35.222	35.233	35.244	35.255	35.266	35.277	35.288	2130
2140	35.288	35.299	35.310	35.321	35.332	35.343	35.354	35.365	35.376	35.387	35.398	2140
2150	35.398	35.409	35.420	35.430	35.441	35.452	35.463	35.474	35.485	35.496	35.506	2150
2160	35.506	35.517	35.528	35.539	35.550	35.561	35.571	35.582	35.593	35.604	35.614	2160
2170	35.614	35.625	35.636	35.647	35.657	35.668	35.679	35.689	35.700	35.711	35.721	2170
2180	35.721	35.732	35.742	35.753	35.764	35.774	35.785	35.795	35.806	35.817	35.827	2180
2190	35.827	35.838	35.848	35.859	35.869	35.880	35.890	35.901	35.911	35.922	35.932	2190
2200	35.932	35.942	35.953	35.963	35.974	35.984	35.995	36.005	36.015	36.026	36.036	2200
2210	36.036	36.046	36.057	36.067	36.077	36.088	36.098	36.108	36.118	36.129	36.139	2210
2220	36.139	36.149	36.159	36.169	36.180	36.190	36.200	36.210	36.220	36.231	36.241	2220
2230	36.241	36.251	36.261	36.271	36.281	36.291	36.301	36.311	36.321	36.331	36.341	2230
2240	36.341	36.351	36.361	36.371	36.381	36.391	36.401	36.411	36.421	36.431	36.441	2240
2250	36.441	36.451	36.461	36.471	36.481	36.491	36.500	36.510	36.520	36.530	36.540	2250
2260	36.540	36.549	36.559	36.569	36.579	36.589	36.598	36.608	36.618	36.627	36.637	2260
2270	36.637	36.647	36.656	36.666	36.676	36.685	36.695	36.705	36.714	36.724	36.733	2270
2280	36.733	36.743	36.753	36.762	36.772	36.781	36.791	36.800	36.810	36.819	36.829	2280
2290	36.829	36.838	36.847	36.857	36.866	36.876	36.885	36.895	36.904	36.913	36.923	2290
2300	36.923	36.932	36.941	36.951	36.960	36.969	36.978	36.988	36.997	37.006	37.015	2300
2310	37.015	37.025	37.034	37.043	37.052	37.061						3210
°C	0	1	2	3	4	5	6	7	8	9	10	°C

تطبيقات عملية على استخدام الـ RTD مع أجهزة القياس الديجيتال

DE Series, 1/8 DIN Digital Thermostats



MODEL NUMBER	VOLTS	MAX. AMPS	TEMP. RANGE	SENSOR LENGTH	REPL. SENSOR P/N	SHIP WGT. Lbs./ (kg)
DE20	85-265	20	0 to 500°F (0 to 260°C)	10' (3 m)	RTD1000	3 (1.5)

** [Thermal Protection Systems](#)

Product Features and Benefits:

IMPROVES PROCESS CONTROL: Large (.56" high), easy to read LED display. Provides precise control for consistent plating and etch rates in most aqueous processes.

TEMPERATURE SENSOR: Fluoropolymer (FEP) covered 10-foot (3m), 1000-ohm platinum RTD sensor included standard with the control. Provides extended service in corrosive liquids and can be lengthened with ordinary copper hookup wire.

CAPACITIES:

- Single pole, double throw switch rated at 20-amps for either 120 or 240 volts.
- Adjustable temperature range from -40°F (-40°C) to 999°F (538°C).
- +/- .25% full span, single digit accuracy.
- 20°F (-7°C) to 130°F (54°C) ambient temperature range.
- Universal power supply: 85-265 VAC, 50 or 60 Hz.
- Single phase only.
- Non-volatile memory.
- Programmable high alarm shutdown.
- Sensor short and break protection.
- Programmable high setpoint limit.
- Security code restricted menu.

Eng. Mahmoud Abdel Fatah Ahmed
mahmodcontrol@yahoo.com
Mob. 01148695492

**Power, Heating and Cooling Relay Wiring
(rear view of controller)**

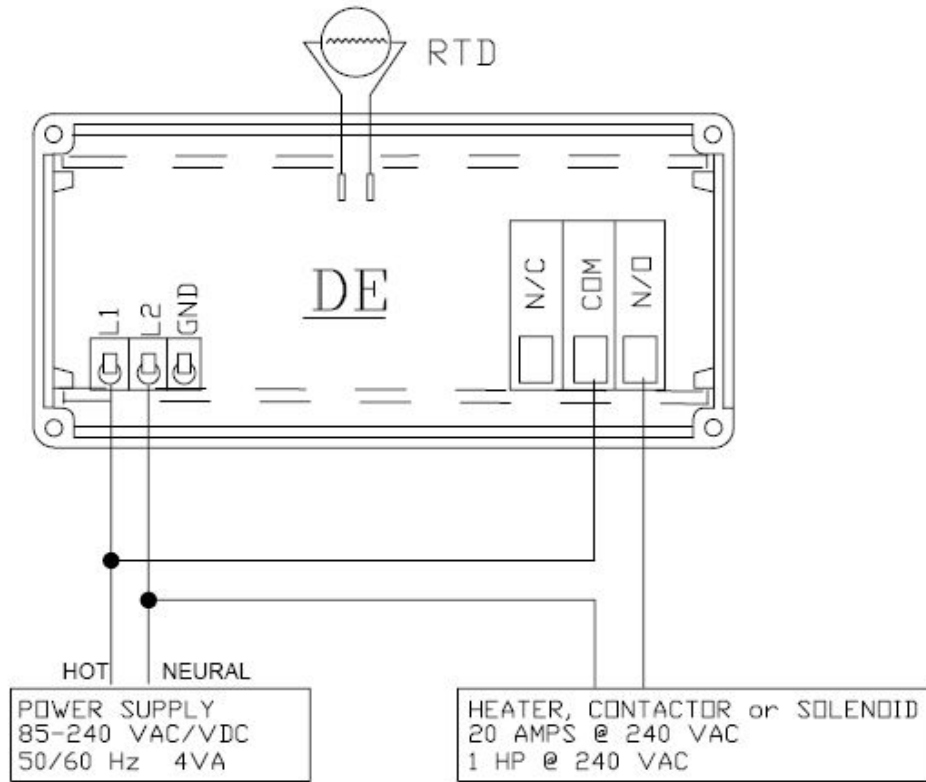

RTD devices are precise resistors whose resistance value varies with temperature. The DE20 control measures the RTD resistance and compares that measurement with a “standard” set of values stored in the control memory.

To restore, update or verify that this “standard” set of values is correct, do the Calibration.

RTD (2- or 3-Wire) 100 (Platinum)

There could be a + 2°F input error for every 1 Ω of lead length resistance when using a 2-wire RTD. That resistance, when added to the RTD element resistance, will result in erroneous input to the instrument. To overcome this problem, use a 3-wire RTD sensor, which compensates for lead length resistance. When extension wire is used for a 3-wire RTD, all wires must have the same electrical resistance (i.e. same gauge, same length, multistranded

العطل Trouble	Occurrence Timing		السبب المحتمل Possible Cause	العلاج Remedy
	Upon Start-- up	During Opera- tion		
An indicationvalue is abnormal. ١٣٧ ٥ ٥٣٧ ٧	○		<ul style="list-style-type: none"> • Faulty resistance value of th resistance element. • Faulty installation of the resistance thermometer sensors. • Type of the receiver or setting of the range is wrong. 	<ul style="list-style-type: none"> • Replace • Check for an installation position, insertion length, and installation method, and reinstall.
		○	<ul style="list-style-type: none"> • Deterioration of insulation of the resistance thermometer sensor or extension conductors. • Change of installation of the resistance thermometer sensor. • Trouble of the receiver. 	<ul style="list-style-type: none"> • Check the insulation resistance, and replace. • Check the insulation, and repair or replace. • Check the receiver , and repair or replace.
An indicationvalue is several percents higher.	○		<ul style="list-style-type: none"> • A "JPt" type resistance thermometer sensor is connected to a "Pt" type instrument. 	<ul style="list-style-type: none"> • Replace with an adequate one which meets the standard.
An indicatiovalue is several percents lower.	○		<ul style="list-style-type: none"> • A "Pt" type resistance thermometersensor is connected to a "JPt" typeinstrument. 	<ul style="list-style-type: none"> • Replace with an adequate one which meets the standard.

Eng. Mahmoud Abdel Fatah Ahmed
mahmodcontrol@yahoo.com
Mob. 01148695492

جدول العلاقة بين قيمة المقاومة الحرارية RTD وبين القيمة المناظرة لدرجة الحرارة °C
المقاومة نوع (Pt100 Platinum □)

Pt°C

TABLE 29 100Ω Platinum RTD — 0.00385 coefficient
temperature in °C

°C	0	1	2	3	4	5	6	7	8	9	10	°C
Resistance in Ohms												
-200	18.52											-200
-190	22.83	22.40	21.97	21.54	21.11	20.68	20.25	19.82	19.38	18.95	18.52	-190
-180	27.10	26.67	26.24	25.82	25.39	24.97	24.54	24.11	23.68	23.25	22.83	-180
-170	31.34	30.91	30.49	30.07	29.64	29.22	28.80	28.37	27.95	27.52	27.10	-170
-160	35.54	35.12	34.70	34.28	33.86	33.44	33.02	32.60	32.18	31.76	31.34	-160
-150	39.72	39.31	38.89	38.47	38.05	37.64	37.22	36.80	36.38	35.96	35.54	-150
-140	43.88	43.46	43.05	42.63	42.22	41.80	41.39	40.97	40.56	40.14	39.72	-140
-130	48.00	47.59	47.18	46.77	46.36	45.94	45.53	45.12	44.70	44.29	43.88	-130
-120	52.11	51.70	51.29	50.88	50.47	50.06	49.65	49.24	48.83	48.42	48.00	-120
-110	56.19	55.79	55.38	54.97	54.56	54.15	53.75	53.34	52.93	52.52	52.11	-110
-100	60.26	59.85	59.44	59.04	58.63	58.23	57.82	57.41	57.01	56.60	56.19	-100
-90	64.30	63.90	63.49	63.09	62.68	62.28	61.88	61.47	61.07	60.66	60.26	-90
-80	68.33	67.92	67.52	67.12	66.72	66.31	65.91	65.51	65.11	64.70	64.30	-80
-70	72.33	71.93	71.53	71.13	70.73	70.33	69.93	69.53	69.13	68.73	68.33	-70
-60	76.33	75.93	75.53	75.13	74.73	74.33	73.93	73.53	73.13	72.73	72.33	-60
-50	80.31	79.91	79.51	79.11	78.72	78.32	77.92	77.52	77.12	76.73	76.33	-50
-40	84.27	83.87	83.48	83.08	82.69	82.29	81.89	81.50	81.10	80.70	80.31	-40
-30	88.22	87.83	87.43	87.04	86.64	86.25	85.85	85.46	85.06	84.67	84.27	-30
-20	92.16	91.77	91.37	90.98	90.59	90.19	89.80	89.40	89.01	88.62	88.22	-20
-10	96.09	95.69	95.30	94.91	94.52	94.12	93.73	93.34	92.95	92.55	92.16	-10
0	100.00	99.61	99.22	98.83	98.44	98.04	97.65	97.26	96.87	96.48	96.09	0
0	100.00	100.39	100.78	101.17	101.56	101.95	102.34	102.73	103.12	103.51	103.90	0
10	103.90	104.29	104.68	105.07	105.46	105.85	106.24	106.63	107.02	107.40	107.79	10
20	107.79	108.18	108.57	108.96	109.35	109.73	110.12	110.51	110.90	111.29	111.67	20
30	111.67	112.06	112.45	112.83	113.22	113.61	114.00	114.38	114.77	115.15	115.54	30
40	115.54	115.93	116.31	116.70	117.08	117.47	117.86	118.24	118.63	119.01	119.40	40
50	119.40	119.78	120.17	120.55	120.94	121.32	121.71	122.09	122.47	122.86	123.24	50
60	123.24	123.63	124.01	124.39	124.78	125.16	125.54	125.93	126.31	126.69	127.08	60
70	127.08	127.46	127.84	128.22	128.61	128.99	129.37	129.75	130.13	130.52	130.90	70
80	130.90	131.28	131.66	132.04	132.42	132.80	133.18	133.57	133.95	134.33	134.71	80
90	134.71	135.09	135.47	135.85	136.23	136.61	136.99	137.37	137.75	138.13	138.51	90
100	138.51	138.88	139.26	139.64	140.02	140.40	140.78	141.16	141.54	141.91	142.29	100
110	142.29	142.67	143.05	143.43	143.80	144.18	144.56	144.94	145.31	145.69	146.07	110
120	146.07	146.44	146.82	147.20	147.57	147.95	148.33	148.70	149.08	149.46	149.83	120
130	149.83	150.21	150.58	150.96	151.33	151.71	152.08	152.46	152.83	153.21	153.58	130
140	153.58	153.96	154.33	154.71	155.08	155.46	155.83	156.20	156.58	156.95	157.33	140
150	157.33	157.70	158.07	158.45	158.82	159.19	159.56	159.94	160.31	160.68	161.05	150
160	161.05	161.43	161.80	162.17	162.54	162.91	163.29	163.66	164.03	164.40	164.77	160
170	164.77	165.14	165.51	165.89	166.26	166.63	167.00	167.37	167.74	168.11	168.48	170
180	168.48	168.85	169.22	169.59	169.96	170.33	170.70	171.07	171.43	171.80	172.17	180
190	172.17	172.54	172.91	173.28	173.65	174.02	174.38	174.75	175.12	175.49	175.86	190
200	175.86	176.22	176.59	176.96	177.33	177.69	178.06	178.43	178.79	179.16	179.53	200
210	179.53	179.89	180.26	180.63	180.99	181.36	181.72	182.09	182.46	182.82	183.19	210
220	183.19	183.55	183.92	184.28	184.65	185.01	185.38	185.74	186.11	186.47	186.84	220
230	186.84	187.20	187.56	187.93	188.29	188.66	189.02	189.38	189.75	190.11	190.47	230
240	190.47	190.84	191.20	191.56	191.92	192.29	192.65	193.01	193.37	193.74	194.10	240
250	194.10	194.46	194.82	195.18	195.55	195.91	196.27	196.63	196.99	197.35	197.71	250
260	197.71	198.07	198.43	198.79	199.15	199.51	199.87	200.23	200.59	200.95	201.31	260
270	201.31	201.67	202.03	202.39	202.75	203.11	203.47	203.83	204.19	204.55	204.90	270
280	204.90	205.26	205.62	205.98	206.34	206.70	207.05	207.41	207.77	208.13	208.48	280
290	208.48	208.84	209.20	209.56	209.91	210.27	210.63	210.98	211.34	211.70	212.05	290

TABLE 29 100 Ω Platinum RTD — 0.00385 coefficient
temperature in °C

°C	0	1	2	3	4	5	6	7	8	9	10	°C
Resistance in Ohms												
300	212.05	212.41	212.76	213.12	213.48	213.83	214.19	214.54	214.90	215.25	215.61	300
310	215.61	215.96	216.32	216.67	217.03	217.38	217.74	218.09	218.44	218.80	219.15	310
320	219.15	219.51	219.86	220.21	220.57	220.92	221.27	221.63	221.98	222.33	222.68	320
330	222.68	223.04	223.39	223.74	224.09	224.45	224.80	225.15	225.50	225.85	226.21	330
340	226.21	226.56	226.91	227.26	227.61	227.96	228.31	228.66	229.02	229.37	229.72	340
350	229.72	230.07	230.42	230.77	231.12	231.47	231.82	232.17	232.52	232.87	233.21	350
360	233.21	233.56	233.91	234.26	234.61	234.96	235.31	235.66	236.00	236.35	236.70	360
370	236.70	237.05	237.40	237.74	238.09	238.44	238.79	239.13	239.48	239.83	240.18	370
380	240.18	240.52	240.87	241.22	241.56	241.91	242.26	242.60	242.95	243.29	243.64	380
390	243.64	243.99	244.33	244.68	245.02	245.37	245.71	246.06	246.40	246.75	247.09	390
400	247.09	247.44	247.78	248.13	248.47	248.81	249.16	249.50	249.85	250.19	250.53	400
410	250.53	250.88	251.22	251.56	251.91	252.25	252.59	252.93	253.28	253.62	253.96	410
420	253.96	254.30	254.65	254.99	255.33	255.67	256.01	256.35	256.70	257.04	257.38	420
430	257.38	257.72	258.06	258.40	258.74	259.08	259.42	259.76	260.10	260.44	260.78	430
440	260.78	261.12	261.46	261.80	262.14	262.48	262.82	263.16	263.50	263.84	264.18	440
450	264.18	264.52	264.86	265.20	265.53	265.87	266.21	266.55	266.89	267.22	267.56	450
460	267.56	267.90	268.24	268.57	268.91	269.25	269.59	269.92	270.26	270.60	270.93	460
470	270.93	271.27	271.61	271.94	272.28	272.61	272.95	273.29	273.62	273.96	274.29	470
480	274.29	274.63	274.96	275.30	275.63	275.97	276.30	276.64	276.97	277.31	277.64	480
490	277.64	277.98	278.31	278.64	278.98	279.31	279.64	279.98	280.31	280.64	280.98	490
500	280.98	281.31	281.64	281.98	282.31	282.64	282.97	283.31	283.64	283.97	284.30	500
510	284.30	284.63	284.97	285.30	285.63	285.96	286.29	286.62	286.95	287.29	287.62	510
520	287.62	287.95	288.28	288.61	288.94	289.27	289.60	289.93	290.26	290.59	290.92	520
530	290.92	291.25	291.58	291.91	292.24	292.56	292.89	293.22	293.55	293.88	294.21	530
540	294.21	294.54	294.86	295.19	295.52	295.85	296.18	296.50	296.83	297.16	297.49	540
550	297.49	297.81	298.14	298.47	298.80	299.12	299.45	299.78	300.10	300.43	300.75	550
560	300.75	301.08	301.41	301.73	302.06	302.38	302.71	303.03	303.36	303.69	304.01	560
570	304.01	304.34	304.66	304.98	305.31	305.63	305.96	306.28	306.61	306.93	307.25	570
580	307.25	307.58	307.90	308.23	308.55	308.87	309.20	309.52	309.84	310.16	310.49	580
590	310.49	310.81	311.13	311.45	311.78	312.10	312.42	312.74	313.06	313.39	313.71	590
600	313.71	314.03	314.35	314.67	314.99	315.31	315.64	315.96	316.28	316.60	316.92	600
610	316.92	317.24	317.56	317.88	318.20	318.52	318.84	319.16	319.48	319.80	320.12	610
620	320.12	320.43	320.75	321.07	321.39	321.71	322.03	322.35	322.67	322.98	323.30	620
630	323.30	323.62	323.94	324.26	324.57	324.89	325.21	325.53	325.84	326.16	326.48	630
640	326.48	326.79	327.11	327.43	327.74	328.06	328.38	328.69	329.01	329.32	329.64	640
650	329.64	329.96	330.27	330.59	330.90	331.22	331.53	331.85	332.16	332.48	332.79	650
660	332.79											660